

# WBL Series

## WBL 810



8 l/m  
2.1 USGPM



max 100 BAR  
1450 P.S.I.

### APPLICAZIONI - APPLICATIONS



MANUTENZIONE  
MAINTENANCE



PROCESSI INDUSTRIALI  
INDUSTRIAL PROCESSES



AUTOLAVAGGIO  
CARWASH



EDILIZIA  
CONSTRUCTION



SANIFICAZIONE  
SANITIZATION

### TECHNICAL PLUS:



USCITA ALBERO DX  
RIGHT DRIVE SHAFT



CARTER REVERSIBILE, PER USCITA ALBERO SX O DX  
REVERSIBLE CRANKCASE FOR LEFT OR RIGHT



BIELLE IN LEGA TONOLLI 328  
CONRODS IN HYPER 328 TONOLLI ALLOY



GUARNIZIONI TENUTA ACQUA NBR (BUNA)  
NBR (BUNA) WATER SEALS

### OPTIONAL:



USCITA ALBERO LATO SX  
LEFT DRIVE SHAFT



BIELLE IN BRONZO  
BRONZE CONRODS



FLANGIA E GIUNTO ELASTICO PER MOT. ELETT. B3 -B14  
BELL HOUSING AND FLEXIBLE COUPLING FOR ELECTRIC  
MOTOR B3 -B14

### GUARNIZIONI - SEALS



GUARNIZIONI ANTERIORI  
"V" - POSTERIORI "U"  
"V" FRONT SEALS - "U" BACK SEALS

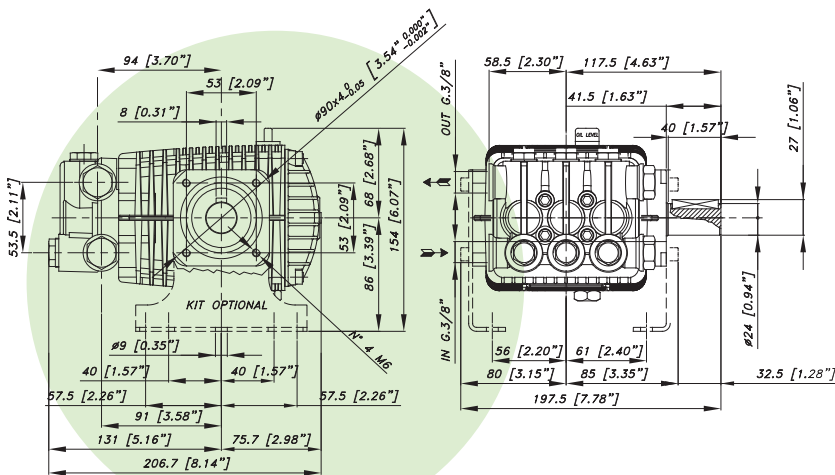

### CARATTERISTICHE TECNICHE SPECIFICATIONS

<b>Peso - Weight</b>	<b>5,8 Kg</b>	12.8 lb
<b>IN</b>	<b>3/8 BSP</b>	
<b>Pressione Min - Min Pressure</b>	<b>-0,1 BAR</b>	-1.5 P.S.I.
<b>Pressione Max - Max Pressure</b>	<b>6 BAR</b>	87 P.S.I.
<b>OUT</b>	<b>3/8 BSP</b>	
<b>Albero - Shaft</b>	<b>Ø 24 mm</b>	
<b>Max. Temperatura - Max. Temperature</b>	<b>60 °C</b>	140 °F
<b>Tipo olio - Oil type</b>	<b>SAE 75 - W 90</b>	
<b>Capacità olio - Oil capacity</b>	<b>0,5 lt</b>	0.13 U.S.G.

WBL Series  
**WBL 810**

	8 l/m 2.1 USGPM		max 100 BAR 1450 P.S.I.
---	--------------------	---	----------------------------

CODICE CODE	MODELLO MODEL	Press. Max Max Pres.		RPM 1450				Pist. Plung.	Corsa Stroke
				Portata-Flow		Potenza-Power			
		BAR	P.S.I.	L/min	GPM	KW	HP	Dia. mm	mm
02.6000.97.3	WBL 810	100	1450	8	2,1	1,4	1,9	18	7
02.6001.97.3	WBL 813	130	1900	8	2,1	1,9	2,5	18	7
02.6002.97.3	WBL 816	160	2300	8	2,1	2,2	3	18	7
02.6003.97.3	WBL 911	110	1600	9	2,3	1,8	2,4	18	8
02.6004.97.3	WBL 913	130	1900	9	2,3	2,1	2,8	18	8
02.6005.97.3	WBL 917	170	2400	9	2,3	2,7	3,6	18	8
02.6006.97.3	WBL 1010	100	1450	10	2,6	1,9	2,5	18	9,2
02.6007.97.3	WBL 1012	120	1750	10	2,6	2,3	3	18	9,2
02.6008.97.3	WBL 1016	160	2300	10	2,6	2,9	3,9	18	9,2
02.6009.97.3	WBL 1109	90	1300	11	2,9	1,8	2,5	18	10
02.6010.97.3	WBL 1111	110	1600	11	2,9	2,2	3	18	10
02.6011.97.3	WBL 1115	150	2200	11	2,9	3	4	18	10
02.6012.97.3	WBL 1312	120	1750	13	3,4	3	4	18	12,4