

# WBL-F Series

## WBL 1010-F



10 l/m  
2.6 USGPM



max 100 BAR  
1450 P.S.I.

### APPLICAZIONI - APPLICATIONS



**MANUTENZIONE**  
MAINTENANCE



**PROCESSI INDUSTRIALI**  
INDUSTRIAL PROCESSES



**AUTOLAVAGGIO**  
CARWASH



**EDILIZIA**  
CONSTRUCTION



**SANIFICAZIONE**  
SANITIZATION

### TECHNICAL PLUS:



**USCITA ALBERO DX**  
RIGHT DRIVE SHAFT



**CARTER REVERSIBILE, PER USCITA ALBERO SX O DX**  
REVERSIBLE CRANKCASE FOR LEFT OR RIGHT



**BIELLE IN LEGA TONOLLI 328**  
CONRODS IN HYPER 328 TONOLLI ALLOY



**GUARNIZIONI TENUTA ACQUA NBR (BUNA)**  
NBR (BUNA) WATER SEALS

### OPTIONAL:



**USCITA ALBERO LATO SX**  
LEFT DRIVE SHAFT



**BIELLE IN BRONZO**  
BRONZE CONRODS



**FLANGIA E GIUNTO ELASTICO PER MOT. ELETT. B3 -B14**  
BELL HOUSING AND FLEXIBLE COUPLING FOR ELECTRIC MOTOR B3 -B14

### GUARNIZIONI - SEALS



**GUARNIZIONI ANTERIORI**  
"V" - POSTERIORI "U"  
"V" FRONT SEALS - "U" BACK SEALS

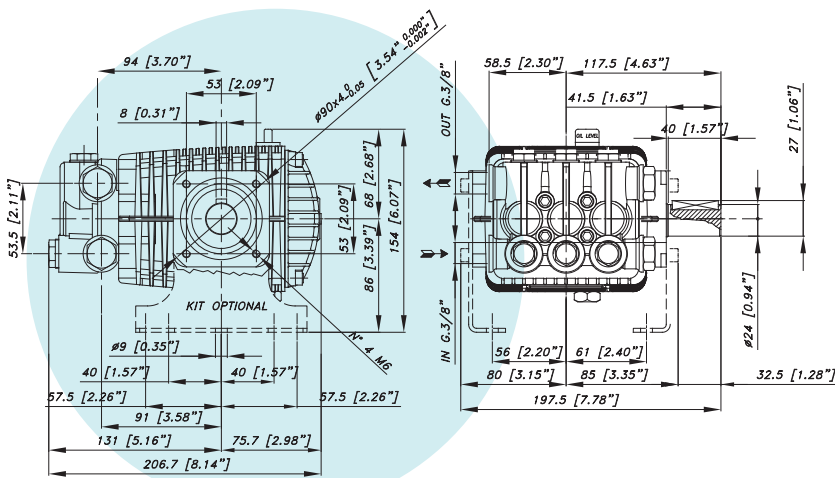

### CARATTERISTICHE TECNICHE SPECIFICATIONS

<b>Peso - Weight</b>	<b>5,8 Kg</b>	12.8 lb
<b>IN</b>	<b>3/8 BSP</b>	
<b>Pressione Min - Min Pressure</b>	<b>1 BAR</b>	15 P.S.I.
<b>Pressione Max - Max Pressure</b>	<b>6 BAR</b>	87 P.S.I.
<b>OUT</b>	<b>3/8 BSP</b>	
<b>Albero - Shaft</b>	<b><math>\varnothing</math> 24 mm</b>	
<b>Max. Temperatura - Max. Temperature</b>	<b>60 °C</b>	140 °F
<b>Tipo olio - Oil type</b>	<b>SAE 75 - W 90</b>	
<b>Capacità olio - Oil capacity</b>	<b>0,5 lt</b>	0.13 U.S.G.



CODICE CODE	MODELLO MODEL	Press. Max Max Pres.		RPM 2800				Pist. Plung.	Corsa Stroke
		BAR	P.S.I.	Portata-Flow		Potenza-Power			
				L/min	GPM	KW	HP	Dia. mm	mm
02.6020.97.3	WBL 809-F	90	1300	8	2,1	1,4	1,9	15	6
02.6021.97.3	WBL 812-F	120	1750	8	2,1	1,9	2,5	15	6
02.6022.97.3	WBL 814-F	140	2000	8	2,1	2,2	2,9	15	6
02.6023.97.3	WBL 1010-F	100	1450	10	2,6	1,8	2,5	15	7
02.6024.97.3	WBL 1012-F	120	1750	10	2,6	2,2	2,9	15	7
02.6025.97.3	WBL 1016-F	160	2300	10	2,6	2,9	3,9	15	7
02.6026.97.3	WBL 1110-F	100	1450	11	2,9	2,1	2,8	15	8
02.6027.97.3	WBL 1114-F	140	2000	11	2,9	2,9	3,9	15	8
02.6028.97.3	WBL 1309-F	90	1300	13	3,4	2,2	2,9	15	9,2
02.6029.97.3	WBL 1312-F	120	1750	13	3,4	2,8	3,8	15	9,2
02.6032.97.3	WBL 1410-F	110	1600	14	3,7	2,9	3,9	15	10