

# WMC/WMC-F Series

## WMC 1520-F



15 l/m  
3.96 USGPM



max 200 BAR  
2900 P.S.I.

### APPLICAZIONI - APPLICATIONS



MANUTENZIONE  
MAINTENANCE



PROCESSI INDUSTRIALI  
INDUSTRIAL PROCESSES



AUTOLAVAGGIO  
CARWASH



EDILIZIA  
CONSTRUCTION



SANIFICAZIONE  
SANITIZATION

### TECHNICAL PLUS:



USCITA ALBERO DX  
RIGHT DRIVE SHAFT



CARTER REVERSIBILE, PER USCITA ALBERO SX O DX  
REVERSIBLE CRANKCASE FOR LEFT OR RIGHT



BIELLE IN BRONZO  
BRONZE CONRODS



GUARNIZIONI TENUTA ACQUA NBR (BUNA)  
NBR (BUNA) WATER SEALS

### OPTIONAL:



USCITA ALBERO LATO SX  
LEFT DRIVE SHAFT

### GUARNIZIONI - SEALS



GUARNIZIONI ANTERIORI  
"V" - POSTERIORI "U"  
"V" FRONT SEALS - "U" BACK SEALS

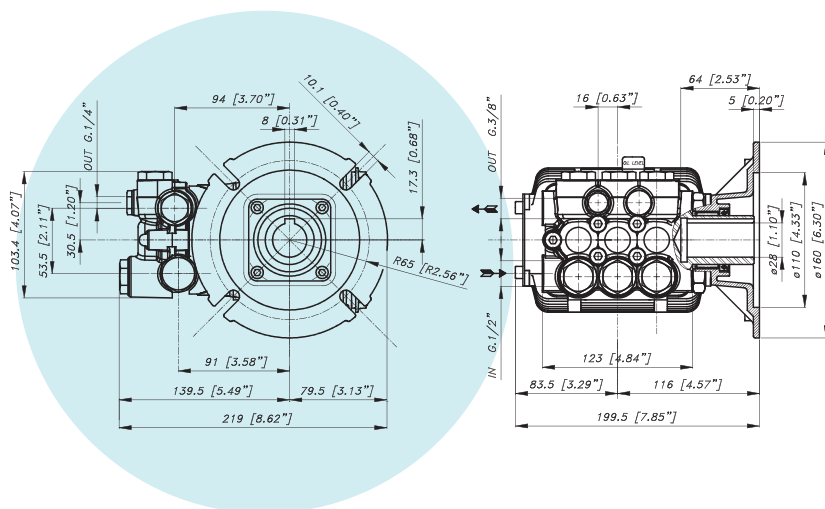

### CARATTERISTICHE TECNICHE SPECIFICATIONS

<b>Peso - Weight</b>	<b>7,6 Kg</b>	16.7 lb
<b>IN</b>	<b>1/2 BSP</b>	
<b>Pressione Min - Min Pressure</b>	<b>1 BAR</b>	15 P.S.I.
<b>Pressione Max - Max Pressure</b>	<b>6 BAR</b>	87 P.S.I.
<b>OUT</b>	<b>3/8 BSP</b>	
<b>Albero - Shaft</b>	<b>HOLLOW Ø 28 mm</b>	
<b>Max. Temperatura - Max. Temperature</b>	<b>60 °C</b>	140 °F
<b>Tipo olio - Oil type</b>	<b>SAE 75 - W 90</b>	
<b>Capacità olio - Oil capacity</b>	<b>0,6 lt</b>	0.16 U.S.G.
<b>Predisposta per motore - For Motor</b>	<b>IEC 100-112 B14-28 mm</b>	

WMC/WMC-F Series  
**WMC 1520-F**



15 l/m  
3.96 USGPM



max 200 BAR  
2900 P.S.I.

CODICE CODE	MODELLO MODEL	Press. Max Max Pres.		RPM 2800				Pist. Plung.	Corsa Stroke
				Portata-Flow		Potenza-Power			
		BAR	P.S.I.	L/min	GPM	KW	HP	Dia. mm	mm
04.8060.97.3	WMC 1114-F	140	2000	11	2,9	2,9	4	15	8
04.8061.97.3	WMC 1120-F	200	2900	11	2,9	4	5,5	15	8
04.8062.97.3	WMC 1316-F	160	2350	13	3,43	4	5,5	15	9,8
04.8063.97.3	WMC 1320-F	200	2900	13	3,43	5,1	7	15	9,8
04.8064.97.3	WMC 1515-F	150	2200	15	3,96	4	5,5	15	10,8
04.8065.97.3	WMC 1520-F	200	2900	15	3,96	5,5	7,5	15	10,8