

WMC/WMC-F Series

WMC 1317



13 l/m
3.4 USGPM



max 170 BAR
2500 P.S.I.

APPLICAZIONI - APPLICATIONS



MANUTENZIONE
MAINTENANCE



PROCESSI INDUSTRIALI
INDUSTRIAL PROCESSES



AUTOLAVAGGIO
CARWASH



EDILIZIA
CONSTRUCTION



SANIFICAZIONE
SANITIZATION

TECHNICAL PLUS:



USCITA ALBERO DX
RIGHT DRIVE SHAFT



CARTER REVERSIBILE, PER USCITA ALBERO SX O DX
REVERSIBLE CRANKCASE FOR LEFT OR RIGHT



BIELLE IN LEGA TONOLLI 328
CONRODS IN HYPER 328 TONOLLI ALLOY



GUARNIZIONI TENUTA ACQUA NBR (BUNA)
NBR (BUNA) WATER SEALS

OPTIONAL:



USCITA ALBERO LATO SX
LEFT DRIVE SHAFT



BIELLE IN BRONZO
BRONZE CONRODS

GUARNIZIONI - SEALS



GUARNIZIONI ANTERIORI
"V" - POSTERIORI "U"
"V" FRONT SEALS - "U" BACK SEALS

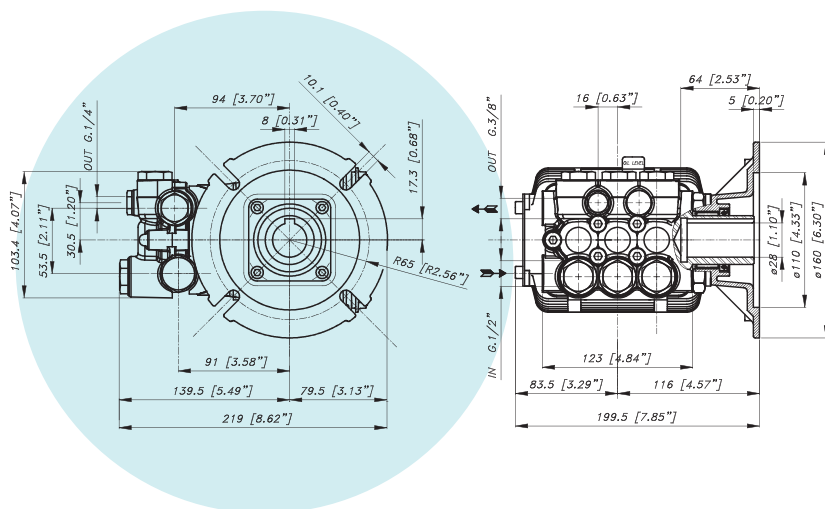

CARATTERISTICHE TECNICHE SPECIFICATIONS

| | | |
|--|------------------------------|-------------|
| Peso - Weight | 7,6 Kg | 16.7 lb |
| IN | 1/2 BSP | |
| Pressione Min - Min Pressure | -0,1 BAR | -1.5 P.S.I. |
| Pressione Max - Max Pressure | 6 BAR | 87 P.S.I. |
| OUT | 3/8 BSP | |
| Albero - Shaft | HOLLOW Ø 28 mm | |
| Max. Temperatura - Max. Temperature | 60 °C | 140 °F |
| Tipo olio - Oil type | SAE 75 - W 90 | |
| Capacità olio - Oil capacity | 0,6 lt | 0.16 U.S.G. |
| Predisposta per motore - For Motor | IEC 100-112 B14-28 mm | |

13 l/m
3.4 USGPMmax 170 BAR
2500 P.S.I.

| CODICE CODE | MODELLO MODEL | Press. Max Max Pres. | | RPM 1450 | | | | Pist. Plung. | Corsa Stroke |
|----------------|------------------|-------------------------|--------|--------------|-----|---------------|-----|-----------------|-----------------|
| | | | | Portata-Flow | | Potenza-Power | | | |
| | | BAR | P.S.I. | L/min | GPM | KW | HP | Dia. mm | mm |
| 04.8050.97.3 | WMC 1117 | 170 | 2500 | 11 | 2,9 | 3,3 | 4,5 | 18 | 9,8 |
| 04.8051.97.3 | WMC 1217 | 170 | 2500 | 12 | 3,1 | 3,6 | 5 | 18 | 10,8 |
| 04.8052.97.3 | WMC 1317 | 170 | 2500 | 13 | 3,4 | 4 | 5,5 | 18 | 12,4 |
| 04.8053.97.3 | WMC 1515 | 150 | 2200 | 15 | 3,9 | 4 | 5,5 | 18 | 13,6 |