

# TML F Series

## TML 2028-F



20 l/m  
5.3 USGPM



max 280 BAR  
4060 P.S.I.

### APPLICAZIONI - APPLICATIONS



MANUTENZIONE  
MAINTENANCE



PROCESSI INDUSTRIALI  
INDUSTRIAL PROCESSES



AUTOLAVAGGIO  
CARWASH



EDILIZIA  
CONSTRUCTION



SANIFICAZIONE  
SANITIZATION

### TECHNICAL PLUS:



USCITA ALBERO DX  
RIGHT DRIVE SHAFT



CARTER REVERSIBILE, PER USCITA ALBERO SX O DX  
REVERSIBLE CRANKCASE FOR LEFT OR RIGHT



BIELLE IN BRONZO  
BRONZE CONRODS



GUARNIZIONI TENUTA ACQUA NBR (BUNA)  
NBR (BUNA) WATER SEALS

### OPTIONAL:



USCITA ALBERO LATO SX  
LEFT DRIVE SHAFT



FLANGIA E BUNTO ELASTICO PER MOTORE  
ELETTRICO B3 - B14  
BELL HOUSING AND FLEXIBLE COUPLING  
FOR ELECTRIC MOTOR B3 - B14



KIT PIEDINI IN LAMIERA  
D'ACCIAIO ZINCATI  
GALVANIZED STEEL  
MOUNTING RAILS KIT

### GUARNIZIONI - SEALS

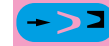

GUARNIZIONI ANTERIORI "U"  
POSTERIORI "V"  
"U" FRONT SEALS - "V" BACK SEALS

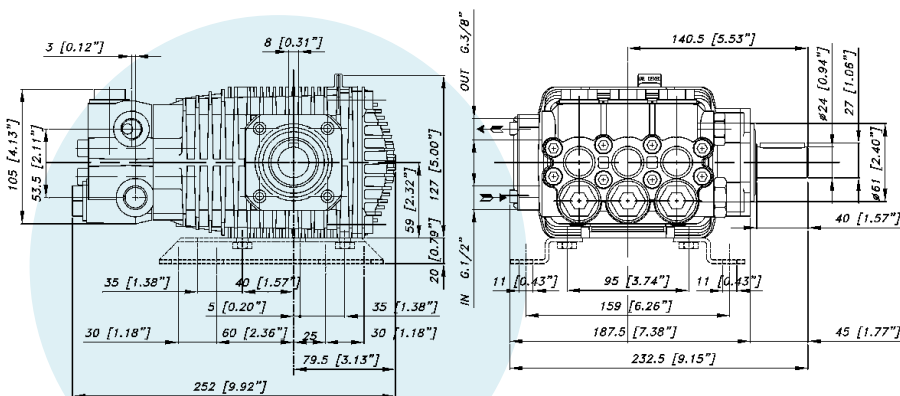

### CARATTERISTICHE TECNICHE SPECIFICATIONS

<b>Peso - Weight</b>	<b>9,5 Kg</b>	21 lb
<b>IN</b>	<b>1/2 BSP</b>	
<b>Pressione Min - Min Pressure</b>	<b>1BAR</b>	15 P.S.I.
<b>Pressione Max - Max Pressure</b>	<b>6 BAR</b>	87 P.S.I.
<b>OUT</b>	<b>3/8 BSP</b>	
<b>Albero - Shaft</b>	<b>Ø 24 mm</b>	
<b>Max. Temperatura - Max. Temperature</b>	<b>60 °C</b>	140 °F
<b>Tipo olio - Oil type</b>	<b>SAE 75 - W 90</b>	
<b>Capacità olio - Oil capacity</b>	<b>0,7 lt</b>	0.18 U.S.G.

20 l/m  
5.3 USGPMmax 280 BAR  
4060 P.S.I.

CODICE CODE	MODELLO MODEL	Press. Max Max Pres.		RPM 1450				RPM 2800				RPM 3450				Pist. Plung.	Corsa Stroke
				Portata-Flow		Potenza-Power		Portata-Flow		Potenza-Power		Portata-Flow		Potenza-Power			
		BAR	P.S.I.	L/min	GPM	KW	HP	L/min	GPM	KW	HP	L/min	GPM	KW	HP	Dia. mm	mm
07.1101.97.A	TML 1528-F	280	4060	8	2,1	4,4	6,0	15	4,0	8,3	11,1	18	4,8	9,8	13,1	15	11,2
07.1104.97.A	TML 1728-F	280	4060	9	2,4	4,9	6,6	17	4,5	9,2	12,3	20	5,3	10,8	14,5	15	12,4
07.1106.97.A	TML 2028-F	280	4060	11	2,9	6,0	8,0	20	5,3	11,1	14,9	24	6,3	13,1	17,6	15	15