

TML-HW Series

TML 1728-HW



17 l/m
4.5 USGPM



max 150 BAR
2175 P.S.I.

APPLICAZIONI - APPLICATIONS



MANUTENZIONE
MAINTENANCE



PROCESSI INDUSTRIALI
INDUSTRIAL PROCESSES



AUTOLAVAGGIO
CARWASH



EDILIZIA
CONSTRUCTION



SANIFICAZIONE
SANITIZATION

TECHNICAL PLUS:



USCITA ALBERO DX
RIGHT DRIVE SHAFT



CARTER REVERSIBILE, PER USCITA ALBERO SX O DX
REVERSIBLE CRANKCASE FOR LEFT OR RIGHT



BIELLE IN BRONZO
BRONZE CONRODS



GUARNIZIONI TENUTA ACQUA NBR (BUNA)
NBR (BUNA) WATER SEALS



PISTONE IN CERAMICA GRANDE SPESSORE PER ACQUA CALDA
INCREASED THICKNESS OF CERAMIC PISTON FOR HOT WATER USE

SPECIAL TRADEMARK:



INTELLIseal H-W™

OPTIONAL:



USCITA ALBERO LATO SX
LEFT DRIVE SHAFT



RIDUTTORE PER MOTORE TERMICO
GEARBOX FOR GAS/DIESEL ENGINE



FLANGIA E GIUNTO ELASTICO PER MOTORE ELETTRICO B3 - B14
BELL HOUSING AND FLEXIBLE COUPLING FOR ELECTRIC MOTOR B3 - B14



KIT PIEDINI IN LAMIERA D'ACCIAIO ZINCATI
GALVANIZED STEEL MOUNTING RAILS KIT

GUARNIZIONI - SEALS



GUARNIZIONI ANT. SUPER "U"
POSTERIORI "U" (PTFE) TEMP.
ACQUA 85°C - 185°F
SUPER "U" FRONT SEALS
PTFE "U" BACK SEALS FOR
WATER TEMPERATURE 85°C - 185°F

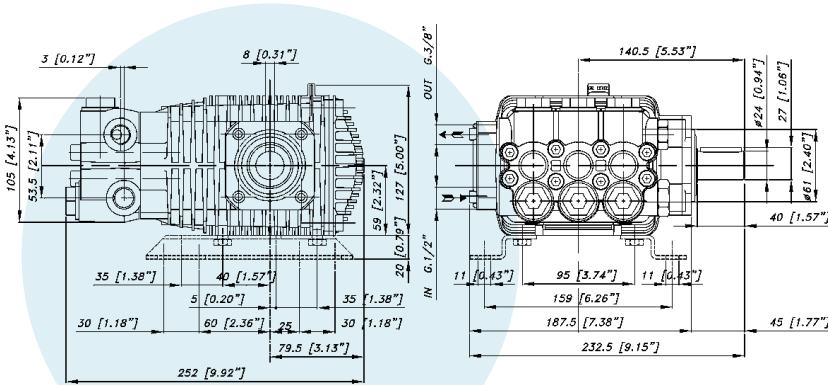

CARATTERISTICHE TECNICHE SPECIFICATIONS

Peso - Weight	10 Kg	22 lb
IN	1/2 BSP	
Pressione Min - Min Pressure	-0.1BAR	-1.5 P.S.I.
Pressione Max - Max Pressure	6 BAR	87 P.S.I.
OUT	3/8 BSP	
Albero - Shaft	Ø 24 mm	
Max. Temperatura - Max. Temperature	85 °C	185 °F
Tipo olio - Oil type	SAE 75 - W 90	
Capacità olio - Oil capacity	0,7 lt	0.18 U.S.G.

17 L/m
4.5 USGPMmax 150 BAR
2175 P.S.I.

CODICE CODE	MODELLO MODEL	Press. Max Max Pres.		RPM 950				RPM 1450				RPM 1725				Pist. Plung.	Corsa Stroke
				Portata-Flow		Potenza-Power		Portata-Flow		Potenza-Power		Portata-Flow		Potenza-Power			
		BAR	P.S.I.	L/min	GPM	KW	HP	L/min	GPM	KW	HP	L/min	GPM	KW	HP	Dia. mm	mm
07.1034.97.A	TML 1328-HW	150	2175	9	2,4	2,5	3,4	13	3,4	3,8	5,1	15	4,0	4,5	6	18	12,4
07.1035.97.A	TML 1528-HW	150	2175	10	2,6	2,9	3,9	15	4,0	4,4	5,9	18	4,8	5,2	6,9	18	14,4
07.1036.97.A	TML 1728-HW	150	2175	11	2,9	3,2	4,3	17	4,5	4,9	6,6	20	5,3	5,8	7,7	18	16
07.1037.97.A	TML 2028-HW	150	2175	13	3,4	3,8	5,1	20	5,3	5,7	7,7	23	6,1	6,7	9	18	18,7
07.1038.97.3	TML 2120-HW	150	2175	14	3,7	4,0	5,4	21	5,5	6,1	8,1	24	6,3	7,2	9,6	20	16
07.1039.97.3	TML 2420-HW	150	2175	16	4,2	4,7	6,3	24	6,3	7,1	9,5	-	-	-	-	20	18,7