

TML HP Series

TML 1528-HP



15 l/m
4.0 USGPM



max 280 BAR
4060 P.S.I.

APPLICAZIONI - APPLICATIONS



MANUTENZIONE
MAINTENANCE



PROCESSI INDUSTRIALI
INDUSTRIAL PROCESSES



AUTOLAVAGGIO
CARWASH



EDILIZIA
CONSTRUCTION



SANIFICAZIONE
SANITIZATION

TECHNICAL PLUS:



USCITA ALBERO DX
RIGHT DRIVE SHAFT



CARTER REVERSIBILE, PER USCITA ALBERO SX O DX
REVERSIBLE CRANKCASE FOR LEFT OR RIGHT



BIELLE IN BRONZO
BRONZE CONRODS



GUARNIZIONI TENUTA ACQUA NBR (BUNA)
NBR (BUNA) WATER SEALS

SPECIAL TRADEMARK:



INTELLiseal™



INTELLiseal H-W™

OPTIONAL:



USCITA ALBERO LATO SX
LEFT DRIVE SHAFT



RIDUTTORE PER MOTORE TERMICO
GEARBOX FOR GAS/DIESEL ENGINE



FLANGIA E GIUNTO ELASTICO PER MOTORE
ELETTRICO B3 - B14
BELL HOUSING AND FLEXIBLE COUPLING
FOR ELECTRIC MOTOR B3 - B14



KIT PIEDINI IN LAMIERA
D'ACCIAIO ZINCATI
GALVANIZED STEEL
MOUNTING RAILS KIT

GUARNIZIONI - SEALS



GUARNIZIONI ANTERIORI SUPER "U"
GUARNIZIONI POSTERIORI "V"
SUPER "U" FRONT SEALS - "V" BACK SEALS

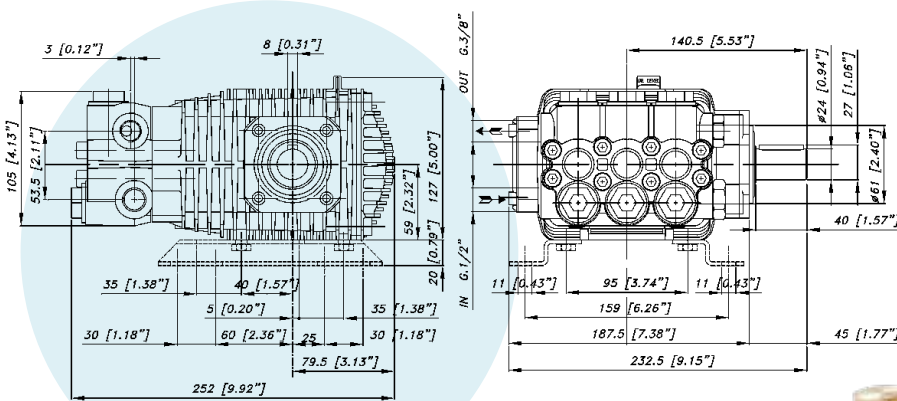

CARATTERISTICHE TECNICHE SPECIFICATIONS

Peso - Weight	10 Kg	22 lb
IN	1/2 BSP	
Pressione Min - Min Pressure	-0,1 BAR	-1.5 P.S.I.
Pressione Max - Max Pressure	6 BAR	87 P.S.I.
OUT	3/8 BSP	
Albero - Shaft	Ø 24 mm	
Max. Temperatura - Max. Temperature	74 °C	165 °F
Tipo olio - Oil type	SAE 75 - W 90	
Capacità olio - Oil capacity	0,7 lt	0.18 U.S.G.

15 l/m
4.0 USGPMmax 280 BAR
4060 P.S.I.

CODICE CODE	MODELLO MODEL	Press. Max Max Pres.		RPM 950				RPM 1450				RPM 1725				Pist. Plung.	Corsa Stroke
				Portata-Flow		Potenza-Power		Portata-Flow		Potenza-Power		Portata-Flow		Potenza-Power			
		BAR	P.S.I.	L/min	GPM	KW	HP	L/min	GPM	KW	HP	L/min	GPM	KW	HP	Dia. mm	mm
07.1051.97.3	TML 1328-HP	280	4060	8	2,1	4,6	6,2	13	3,4	7,0	9,4	15	4,0	8,2	11,0	18	12,4
07.1052.97.3	TML 1528-HP	280	4060	10	2,6	5,3	7,1	15	4,0	8,1	10,9	17	4,5	9,5	12,7	18	14,4
07.1053.97.3	TML 1728-HP	280	4060	11	2,9	5,9	7,9	17	4,5	9,2	12,4	19	5,0	10,5	14,1	18	16
07.1054.97.3	TML 2028-HP	280	4060	13	3,4	6,9	9,3	20	5,3	10,9	14,6	23	6,1	12,3	16,5	18	18,7