

TMH/TMH-F Series

TMH 4040-F



15 l/m
4 USGPM



max 280 BAR
4000 P.S.I.

APPLICAZIONI - APPLICATIONS



MANUTENZIONE
MAINTENANCE



PROCESSI INDUSTRIALI
INDUSTRIAL PROCESSES



AUTOLAVAGGIO
CARWASH



EDILIZIA
CONSTRUCTION



SANIFICAZIONE
SANITIZATION

TECHNICAL PLUS:



USCITA ALBERO DX
RIGHT DRIVE SHAFT



CARTER REVERSIBILE, PER USCITA ALBERO SX O DX
REVERSIBLE CRANKCASE FOR LEFT OR RIGHT



BIELLE IN BRONZO
BRONZE CONRODS



GUARNIZIONI TENUTA ACQUA NBR (BUNA)
NBR (BUNA) WATER SEALS

OPTIONAL:



USCITA ALBERO LATO SX
LEFT DRIVE SHAFT

GUARNIZIONI - SEALS



GUARNIZIONI ANTERIORI "Y"
POSTERIORI "U"
"Y" FRONT SEALS - "U" BACK SEALS

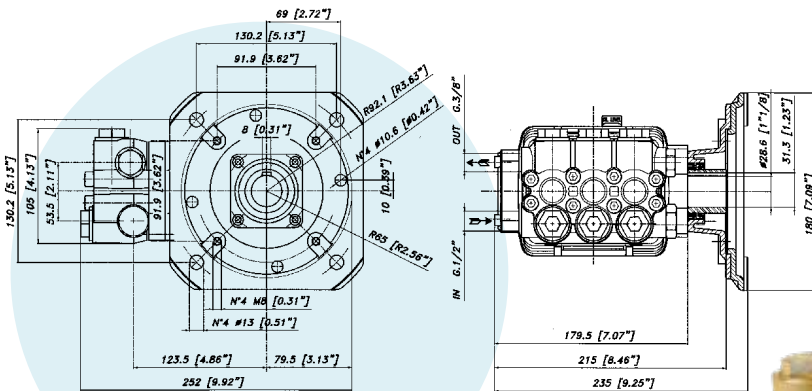

CARATTERISTICHE TECNICHE SPECIFICATIONS

Peso - Weight	10.8 Kg	23.7 lb
IN	Ø 1/2 BSP	
Pressione Min - Min Pressure	-0.1 BAR	-1.5 P.S.I.
Pressione Max - Max Pressure	6 BAR	87 P.S.I.
OUT	Ø 3/8 BSP	
Albero - Shaft	HOLLOW Ø 1"1/8 mm	
Max. Temperatura - Max. Temperature	60 °C	140 °F
Tipo olio - Oil type	SAE 75 - W 90	
Capacità olio - Oil capacity	0,7 lt	0,18 U.S.G.
Predisposta per motore - For motor	NEMA 184TC-1"1/8	

TMH/TMH-F Series
TMH 4040-F

	15 l/m 4 USGPM		max 280 BAR 4000 P.S.I.
---	-------------------	---	----------------------------

CODICE CODE	MODELLO MODEL	Press. Max Max Pres.		RPM 3450				Pist. Plung.	Corsa Stroke
				Portata-Flow		Potenza-Power			
		BAR	P.S.I.	L/min	GPM	KW	HP	Dia. mm	mm
07.1500.97.A	TMH 3035-F	210	3000	13	3,4	5,5	7,5	15	8,6
07.1501.97.A	TMH 4035-F	280	4000	13	3,4	7	9,5	15	8,6
07.1502.97.A	TMH 2740-F	185	2700	15	4,0	5,5	7,5	15	9,8
07.1503.97.A	TMH 4040-F	280	4000	15	4,0	8,1	11	15	9,8
07.1504.97.A	TMH 3045-F	210	3000	17	4,5	7,4	10	15	11,2
07.1505.97.A	TMH 4045-F	280	4000	17	4,5	9,2	12,5	15	11,2
07.1506.97.A	TMH 2950-F	200	2900	19	5,0	7,4	10	15	12,4
07.1507.97.A	TMH 4050-F	280	4000	19	5,0	10	13,5	15	12,4
07.1508.97.A	TMH 2460-F	170	2400	22	5,8	7,4	10	15	15,4
07.1509.97.A	TMH 3560-F	240	3500	22	5,8	10,7	14,5	15	15,4