

Strip Mini Poly Series

Strip Pump DE

17 L/m
4.5 USGPM



max 20 BAR
290 P.S.I.

APPLICAZIONI - APPLICATIONS



AGRICOLTURA
AGRICULTURE



ORTICOLTURA
HORTICULTURE



CARRIOLE
WHEELBARROWS



GIARDINAGGIO
GARDENING



SERRE
GREENHOUSES



DISINFESTAZIONE
DISINFESTATION

MEMBRANE - MEMBRANES

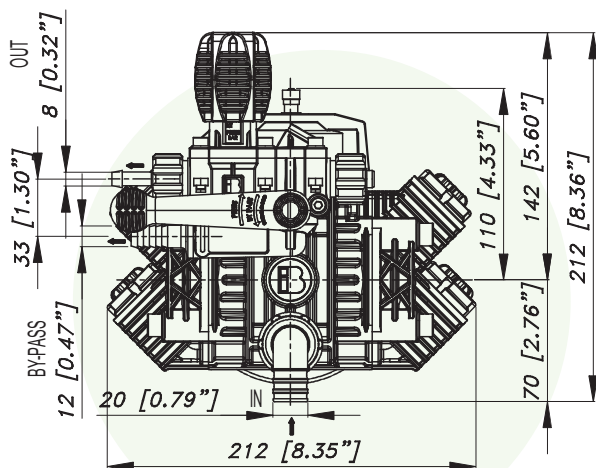

CARATTERISTICHE TECNICHE SPECIFICATIONS

Potenza - Power	0.62 KW	0.83 HP
Peso - Weight	3,5 Kg	7.7 lb
IN	Ø 20 mm	Ø 13/15" in
Pressione Min - Min Pressure	-0,1 BAR	- 1,45 P.S.I.
Pressione Max - Max Pressure	1 BAR	14,5 P.S.I.
OUT	Ø 8 mm	Ø 5/16" in
Max. Temperatura - Max. Temperature	60 °C	140 °F
Tipo olio - Oil type	SAE 30	
Capacità olio - Oil capacity	0,075 lt	0.019 U.S.G.

TABELLA RENDIMENTI PERFORMANCE CHART

g/min R.P.M.	1400	
BAR P.S.I.	L/min USGPM	KW HP
2 29	17,0 4,5	0,08 0,10
10 145	16,0 4,2	0,36 0,48
15 217,5	15,0 4,0	0,50 0,67
20 290	14,0 3,7	0,62 0,83

Versioni Versions

11.7001.97.3 - DE



Strip Mini Poly Series

Strip Pump DE



17 L/m
4.5 USGPM



max 20 BAR
290 P.S.I.

Versioni Versions

11.7001.97.3 - DE

Versione con albero cavo Dia.19 per l'accoppiamento a motori elettrici IEC 80 B14-19mm
Version with hollow shaft diam. 19 mm for direct drive to electric motors IEC 80 B14-19 mm

