

Strip Mini Poly Series

Strip Pump D4



17 L/m
4.5 USGPM



max 20 BAR
290 P.S.I.

APPLICAZIONI - APPLICATIONS



AGRICOLTURA
AGRICULTURE



ORTICOLTURA
HORTICULTURE



CARRIOLE
WHEELBARROWS



GIARDINAGGIO
GARDENING



SERRE
GREENHOUSES



DISINFESTAZIONE
DISINFESTATION

MEMBRANE - MEMBRANES

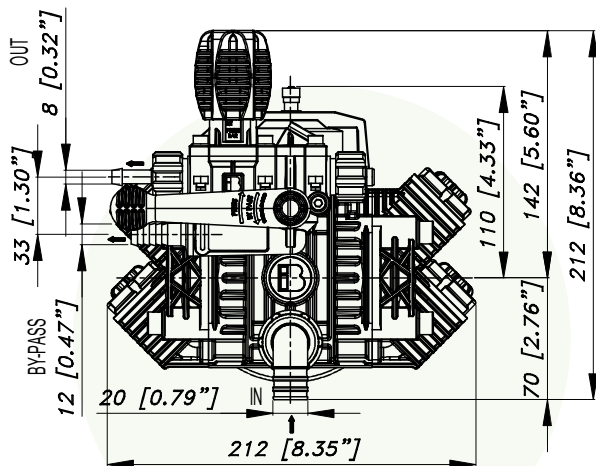

CARATTERISTICHE TECNICHE SPECIFICATIONS

Potenza - Power	0,67 KW	0.89 HP
Peso - Weight	3,5 Kg	7.7 lb
IN	Ø 20 mm	Ø 13/15" in
Pressione Min - Min Pressure	-0,1 BAR	- 1.45 P.S.I.
Pressione Max - Max Pressure	1 BAR	14.5 P.S.I.
OUT	Ø 8 mm	Ø 5/16" in
Max. Temperatura - Max. Temperature	60 °C	140 °F
Tipo olio - Oil type	SAE 30	
Capacità olio - Oil capacity	0,075 lt	0.019 U.S.G.

TABELLA RENDIMENTI PERFORMANCE CHART

g/min R.P.M.	3450	
BAR P.S.I.	L/min USGPM	KW HP
2 29	18,0 4,8	0,08 0,11
10 145	17,0 4,5	0,38 0,51
15 217,5	16,0 4,2	0,53 0,71
20 290	15,0 4,0	0,67 0,89

Versioni Versions

11.7003.97.3-D4	11.7004.97.3-D4	11.7005.97.3-D4

