

# RAL Premium Series

## RAL 1640-P



17 l/m  
4.5 USGPM



max 400 BAR  
5800 P.S.I.

### APPLICAZIONI - APPLICATIONS



**MANUTENZIONE**  
MAINTENANCE



**PROCESSI INDUSTRIALI**  
INDUSTRIAL PROCESSES



**AUTOLAVAGGIO**  
CARWASH



**EDILIZIA**  
CONSTRUCTION



**SANIFICAZIONE**  
SANITIZATION



**IMPIANTI DI VERNICIATURA**  
PAINTING PLANTS



**LAVAGGI**  
WASHING

### TECHNICAL PLUS:



**USCITA ALBERO DX**  
RIGHT DRIVE SHAFT



**PISTONE IN CERAMICA GRANDE SPESSORE PER ACQUA CALDA**  
INCREASED THICKNESS OF CERAMIC PISTON FOR HOT WATER USE



**GUARNIZIONI TENUTA ACQUA NBR (BUNA)**  
NBR (BUNA) WATER SEALS



**BIELLE IN BRONZO**  
BRONZE CONRODS

### SPECIAL TRADEMARK:



**INTELLIseal™**

### OPTIONAL:



**USCITA ALBERO LATO SX**  
LEFT DRIVE SHAFT



**RIDUTTORE PER MOTORE TERMICO**  
GEARBOX FOR GAS/DIESEL ENGINE



**FLANGIA E GIUNTO ELASTICO PER MOTORE ELETTRICO B3 - B14**  
FLANGE HOUSING AND FLEXIBLE COUPLING FOR ELECTRIC MOTOR B3 - B14



**KIT PIEDINI IN LAMIERA D'ACCIAIO ZINCATI**  
GALVANIZED STEEL MOUNTING RAILS KIT

### GUARNIZIONI - SEALS



**GUARNIZIONI ANTERIORI SUPER "U"**  
POSTERIORI "U"  
SUPER "U" FRONT SEALS - "U" BACK SEALS

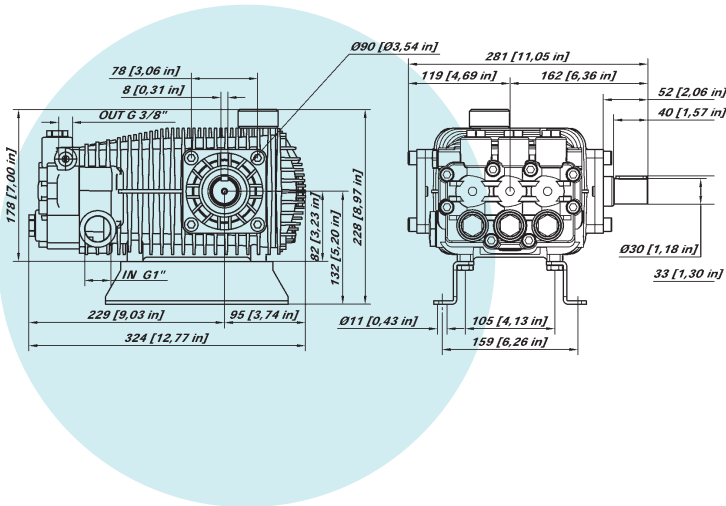

### CARATTERISTICHE TECNICHE

#### SPECIFICATIONS

<b>Peso - Weight</b>	<b>19,5 Kg</b>	43.0 lb
<b>IN</b>	<b>1" BSP</b>	
<b>Pressione Min - Min Pressure</b>	<b>-0,1 BAR</b>	-1.5 P.S.I.
<b>Pressione Max - Max Pressure</b>	<b>6 BAR</b>	87 P.S.I.
<b>OUT</b>	<b>3/8 BSP</b>	
<b>Albero - Shaft</b>	<b>Ø 30 mm</b>	
<b>Max. Temperatura - Max. Temperature</b>	<b>74 °C</b>	165 °F
<b>Tipo olio - Oil type</b>	<b>SAE 75 - W 90</b>	
<b>Capacità olio - Oil capacity</b>	<b>1,5 lt</b>	0.4 U.S.G.

# RAL Premium Series

## RAL 1640-P



17 L/m  
4.5 USGPM



max 400 BAR  
5800 P.S.I.

CODICE CODE	MODELLO MODEL	Press. Max Max Pres.		RPM 950				RPM 1450				RPM 1725				Pist. Plung.	Corsa Stroke
				Portata-Flow		Portata-Flow		Portata-Flow		Potenza-Power		Portata-Flow		Potenza-Power			
		BAR	P.S.I.	L/min	GPM	KW	HP	L/min	GPM	KW	HP	L/min	GPM	KW	HP	Dia. mm	mm
08.1019.97.A	RAL 1640-P	400	5800	11	2,9	8,5	11,5	17	4,5	12,9	17,3	20	5,3	15,2	20,4	18	16
08.1005.97.A	RAL 1840-P	400	5800	12	3,2	9,6	12,9	19	5,0	14,5	19,5	22	5,8	17,1	23,0	18	18
08.1021.97.A	RAL 2035-P	350	5075	14	3,7	9,2	12,4	20	5,3	14,0	18,7	24	6,3	16,4	22,0	20	16
08.1022.97.A	RAL 2335-P	350	5075	15	4,0	10,4	13,9	23	6,1	15,7	21,1	-	-	-	-	20	18

CODICE CODE	MODELLO MODEL	Press. Max Max Pres.		RPM 950				RPM 1200				RPM 1450				Pist. Plung.	Corsa Stroke
				Portata-Flow		Portata-Flow		Portata-Flow		Portata-Flow		Portata-Flow		Portata-Flow			
		BAR	P.S.I.	L/min	GPM	KW	HP	L/min	GPM	KW	HP	L/min	GPM	KW	HP	Dia. mm	mm
08.1000.97.A	RAL 2535-P	350	5075	17	4,5	11,3	15,1	21	5,5	14,1	18,9	25	6,6	16,8	22,6	20	19,5
08.1036.97.A	RAL 2830-P	300	4350	18	4,8	10,8	14,4	23	6,1	13,5	18,1	27	7,1	16,1	21,6	22	18
08.1002.97.A	RAL 3030-P	300	4350	20	5,3	11,5	15,5	25	6,6	14,4	19,4	29	7,7	17,3	23,2	22	19,5

### GRAFICO PRESTAZIONI PERFORMANCE CHART

