

# Poly Series Poly 2260



260 l/m  
68.7 USGPM



max 15 BAR  
218 P.S.I.

## APPLICAZIONI - APPLICATIONS



SPRAYER  
SPRAYER



TRAVASI  
TRANSFERS



DISINFESTAZIONE  
DISINFESTATION

## MEMBRANE - MEMBRANES



DESMOPAN

HPS

VITON

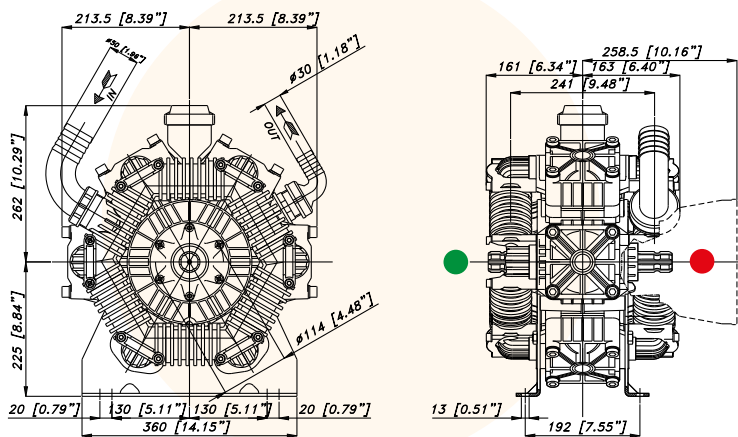

| CARATTERISTICHE TECNICHE<br>SPECIFICATIONS | 550 g/min.<br>550 R.P.M.   |                  | TABELLA RENDIMENTI<br>PERFORMANCE CHART |                |            |                |            |                |            |                |            |
|--|----------------------------|------------------|---|----------------|------------|----------------|------------|----------------|------------|----------------|------------|
|  | Potenza - Power            | 7,4 KW<br>9.8 HP | g/min<br>R.P.M.                         | 400            |            | 450            |            | 500            |            | 550            |            |
| Peso - Weight                              | 39 Kg<br>85.8 lb           |                  | BAR<br>P.S.I.                           | L/min<br>USGPM | KW<br>HP   | L/min<br>USGPM | KW<br>HP   | L/min<br>USGPM | KW<br>HP   | L/min<br>USGPM | KW<br>HP   |
| IN   | Ø 50 mm<br>Ø 2" in         |                  | 2<br>29                                 | 189<br>50,0    | 0,7<br>1,0 | 213<br>56,2    | 0,8<br>1,1 | 236<br>62,4    | 0,9<br>1,2 | 260<br>68,7    | 1,0<br>1,4 |
| Pressione Min - Min Pressure               | -0,15 BAR<br>- 2.17 P.S.I. |                  | 5<br>72,5                               | 188<br>49,6    | 1,8<br>2,5 | 211<br>55,8    | 2,1<br>2,8 | 235<br>62,0    | 2,3<br>3,1 | 258<br>68,2    | 2,5<br>3,4 |
| Pressione Max - Max Pressure               | 1 BAR<br>14.5 P.S.I.       |                  | 10<br>145                               | 185<br>48,8    | 3,6<br>4,8 | 208<br>54,9    | 4,1<br>5,5 | 231<br>61,0    | 4,5<br>6,1 | 254<br>67,1    | 5,0<br>6,7 |
| OUT  | Ø 30 mm<br>Ø 1" 3/16 in    |                  | 15<br>218                               | 182<br>48,0    | 5,4<br>7,2 | 205<br>54,0    | 6,0<br>8,0 | 227<br>60,0    | 6,7<br>8,9 | 250<br>66,1    | 7,4<br>9,8 |
| Max. Temperatura - Max. Temperature        | 60 °C<br>140 °F            |                  |   |                |            |                |            |                |            |                |            |
| Tipo olio - Oil type                       | SAE 30                     |                  |   |                |            |                |            |                |            |                |            |
| Capacità olio - Oil capacity               | 4,36 lt<br>1.12 U.S.G.     |                  |   |                |            |                |            |                |            |                |            |

## Versioni Versions

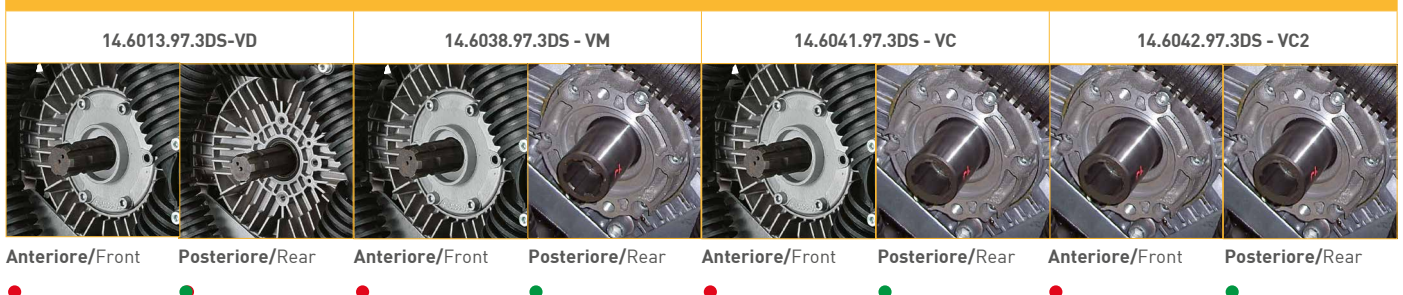

POLY Series

