

Poly Series Poly 2210



210 l/m
55.5 USGPM



max 15 BAR
218 P.S.I.

APPLICAZIONI - APPLICATIONS



SPRAYER
SPRAYER



TRAVASI
TRANSFERS



DISINFESTAZIONE
DISINFESTATION

MEMBRANE - MEMBRANES



DURAMAX

HPS

VITON

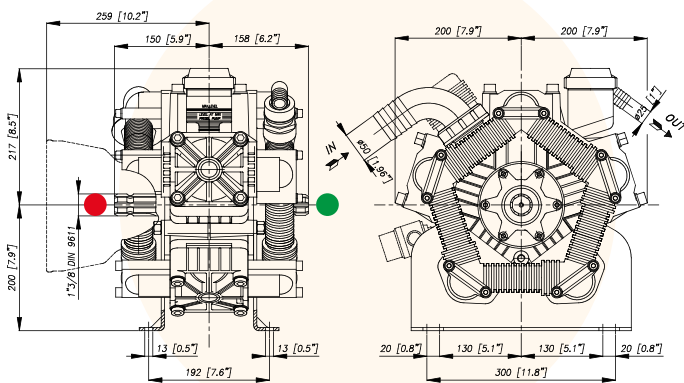

CARATTERISTICHE TECNICHE SPECIFICATIONS

Potenza - Power	6,0 KW	8.0 HP
Peso - Weight	33 Kg	72.6 lb
IN	Ø 50 mm	Ø 2" in
Pressione Min - Min Pressure	-0,15 BAR	- 2.17 P.S.I.
	-0,3 BAR (servizio discontinuo)	-0.435 P.S.I. (discontinuous service)
Pressione Max - Max Pressure	1 BAR	14.5 P.S.I.
OUT	Ø 25 mm	Ø 1" in
Max. Temperatura - Max. Temperature	60 °C	140 °F
Tipo olio - Oil type	SAE 30	
Capacità olio - Oil capacity	3,25 lt	0.85 U.S.G.

TABELLA RENDIMENTI PERFORMANCE CHART

g/min R.P.M.	400		450		500		550	
	BAR P.S.I.	L/min USGPM	KW HP	L/min USGPM	KW HP	L/min USGPM	KW HP	L/min USGPM
2 29	153 29	0,6 0,8	172 45,4	0,7 0,9	191 50,4	0,7 1,0	210 55,5	0,8 1,1
5 72,5	151 40,0	1,5 2,0	170 45,5	1,7 2,2	189 50,0	1,9 2,5	208 55,0	2,0 2,7
10 145	150 39,6	2,9 3,9	169 44,5	3,3 4,4	187 49,5	3,7 4,9	206 54,4	4,0 5,4
15 218	148 39,2	4,4 5,8	167 44,1	4,9 6,6	185 49,0	5,5 7,3	204 53,9	6,0 8,0

Versioni Versions

55.6000.97.3DS - VD		55.6002.97.3DS - VM		55.6015.97.3DS - VC		55.6016.97.3DS-VC2	
Anteriore/Front	Posteriore/Rear	Anteriore/Front	Posteriore/Rear	Anteriore/Front	Posteriore/Rear	Anteriore/Front	Posteriore/Rear
●	●	●	●	●	●	●	●