



Poly Series Poly 2073 VP

75 L/m
19.8 USGPM

max 15 BAR
218 P.S.I.

APPLICAZIONI - APPLICATIONS

-  SPRAYER
SPRAYER
-  SERRE
GREENHOUSES
-  DISINFESTAZIONE
DISINFESTATION

MEMBRANE - MEMBRANES

-  DESMOFAN
-  DURAMAX
-  HPS
-  VITON

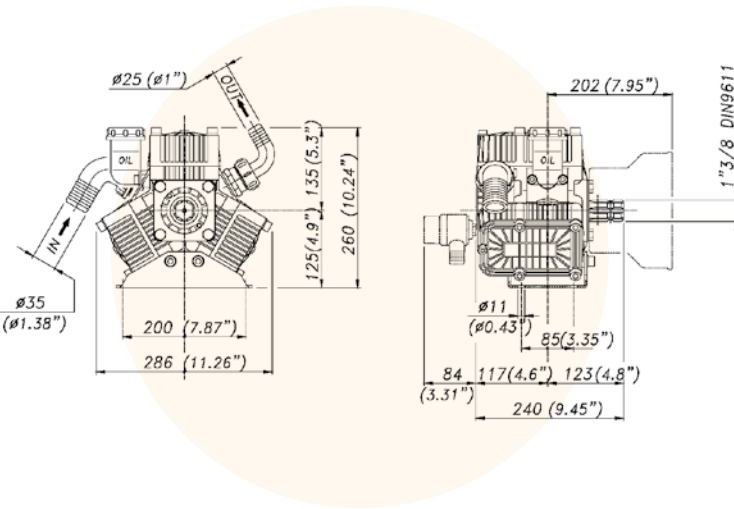

| CARATTERISTICHE TECNICHE SPECIFICATIONS | 650 g/min. 650 R.P.M. | |
|--|------------------------------------|--|
| Potenza - Power | 2,1 KW | 2.8 HP |
| Peso* - Weight* | 11 Kg | 24.2 lb |
| IN | Ø 35 mm | Ø 1" 3/8 in |
| Pressione Min - Min Pressure | -0,15 BAR | - 2.17 P.S.I. |
| | -0.3 BAR (servizio discontinuo) | -0.435 P.S.I. (discontinuous service) |
| Pressione Max - Max Pressure | 1 BAR | 14.5 P.S.I. |
| OUT | Ø 25 mm | Ø 1" in |
| Max. Temperatura - Max. Temperature | 60 °C | 140 °F |
| Tipo olio - Oil type | SAE 30 | |
| Capacità olio - Oil capacity | 0,7 lt | 0.18 U.S.G. |

| TABELLA RENDIMENTI PERFORMANCE CHART | | | | | | | | |
|---|----------------|------------|----------------|------------|----------------|------------|----------------|------------|
| g/min R.P.M. | 400 | | 450 | | 500 | | 550 | |
| BAR P.S.I. | L/min USGPM | KW HP | L/min USGPM | KW HP | L/min USGPM | KW HP | L/min USGPM | KW HP |
| 2 29 | 54,5 14,4 | 0,2 0,3 | 61,4 16,2 | 0,2 0,3 | 68,2 18,0 | 0,3 0,4 | 75,0 19,8 | 0,3 0,4 |
| 5 72,5 | 53,8 14,2 | 0,5 0,7 | 60,5 16,0 | 0,6 0,8 | 67,3 17,8 | 0,7 0,9 | 74,0 19,6 | 0,7 1,0 |
| 10 145 | 52,4 13,8 | 1,0 1,4 | 58,9 15,6 | 1,2 1,5 | 65,5 17,3 | 1,3 1,7 | 72,0 19,0 | 1,4 1,9 |
| 15 218 | 50,9 13,5 | 1,5 2,0 | 57,3 15,1 | 1,7 2,3 | 63,6 16,8 | 1,9 2,5 | 70,0 18,5 | 2,1 2,8 |

* Il peso si riferisce alla sola pompa senza motorizzazione.
* The weight is referred to just the pump without the motor.

| Versioni Versions | Motore elettrico Electric motor | 2073 |
|----------------------|-------------------------------------|--------------|
| VP | Trifase 3,0 KW Threephase 3,0 KW | 63.8001.97.A |