

Strip Mini Poly Series

Poly 2030.1 RTE.1



31 L/m
8.2 USGPM



max 20 BAR
290 P.S.I.

APPLICAZIONI - APPLICATIONS

AGRICOLTURA AGRICULTURE	ORTICOLTURA HORTICULTURE	CARRIOLE WHEELBARROWS
GIARDINAGGIO GARDENING	SERRE GREENHOUSES	DISINFESTAZIONE DISINFESTATION

MEMBRANE - MEMBRANES

BUNA	VITON	DESKOPAN
-------------	--------------	-----------------

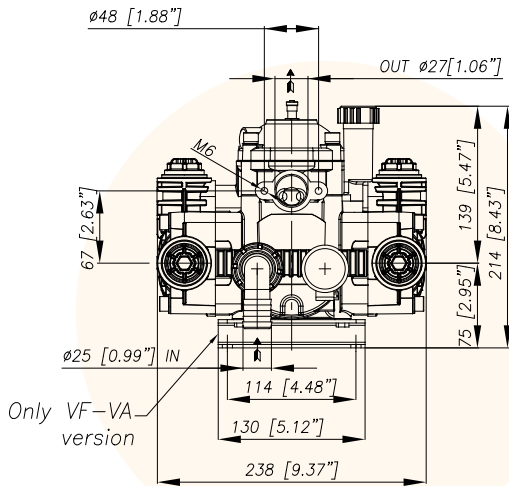

CARATTERISTICHE TECNICHE SPECIFICATIONS	650 g/min. 650 R.P.M.	
Potenza - Power	1,2 KW	1.6 HP
Peso* - Weight*	5,6 Kg	12.3 lb
IN	Ø 25 mm	Ø 1" in
Pressione Min - Min Pressure	-0,1 BAR	-1.45 P.S.I.
Pressione Max - Max Pressure	1 BAR	14.5 P.S.I.
OUT	Ø 8 mm	Ø 5/16" in
Max. Temperatura - Max. Temperature	60 °C	140 °F
Tipo olio - Oil type	SAE 30	
Capacità olio - Oil capacity	0,7 lt	0.18 U.S.G.

TABELLA RENDIMENTI PERFORMANCE CHART								
g/min R,P,M,	500		550		600		650	
	BAR P,S,I,	L/min USGPM	KW HP	L/min USGPM	KW HP	L/min USGPM	KW HP	L/min USGPM
2 29	23,8 6,3	0,11 0,1	26,2 6,9	0,12 0,2	28,6 7,6	0,13 0,2	31,0 8,2	0,14 0,2
10 145	22,3 5,9	0,5 0,7	24,5 6,5	0,5 0,7	26,8 7,1	0,6 0,8	29,0 7,7	0,6 0,9
15 217,5	21,5 5,7	0,7 1,0	23,7 6,3	0,8 1,1	25,8 6,8	0,9 1,2	28,0 7,4	0,9 1,2
20 290	20,8 5,5	0,9 1,2	22,8 6,0	1,0 1,4	24,9 6,6	1,1 1,5	27,0 7,1	1,2 1,6

* Il peso si riferisce alla sola pompa senza motorizzazione.
* The weight is referred to just the pump without the motor.

Versioni Versions	Motore elettrico Electric motor	2030.1
RTE.1	Monofase 1,5 KW Single-phase 1,5 KW	94.8660.97.ADS
	Monofase 2,2 KW Single-phase 2,2 KW	94.74762.97.3
	Trifase 1,5 KW Threephase 1,5 KW	94.7461.97.ADS
	Corrente Continua 12 V 0,6 KW Direct Current 12 V 0,6 KW	94.7464.97.ADS