

Strip Mini Poly Series

# Poly 2025 h.p. RTE.1

27 L/m  
7.1 USGPM

max 20 BAR  
290 P.S.I.

APPLICAZIONI - APPLICATIONS

-  **AGRICOLTURA**  
AGRICULTURE
-  **ORTICOLTURA**  
HORTICULTURE
-  **CARRIOLE**  
WHEELBARROWS
-  **GIARDINAGGIO**  
GARDENING
-  **SERRE**  
GREENHOUSES
-  **DISINFESTAZIONE**  
DISINFESTATION

MEMBRANE - MEMBRANES

-  VITON
-  DESMOPAN
-  BUNA

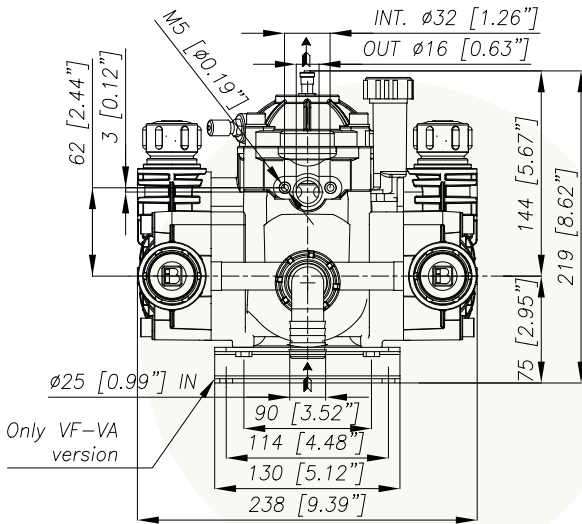

CARATTERISTICHE TECNICHE SPECIFICATIONS	650 g/min. 650 R.P.M.	
<b>Potenza - Power</b>	<b>1,1 KW</b>	1.4 HP
<b>Peso* - Weight*</b>	<b>5,6 Kg</b>	12.3 lb
<b>IN</b>	<b>Ø 25 mm</b>	Ø 1" in
<b>Pressione Min - Min Pressure</b>	<b>-0,1 BAR</b>	-1.45 P.S.I.
<b>Pressione Max - Max Pressure</b>	<b>1 BAR</b>	14.5 P.S.I.
<b>OUT</b>	Predisposizione per accessori Prepared for accessories	
<b>Max. Temperatura - Max. Temperature</b>	<b>60 °C</b>	140 °F
<b>Tipo olio - Oil type</b>	<b>SAE 30</b>	
<b>Capacità olio - Oil capacity</b>	<b>0,7 lt</b>	0.18 U.S.G.

\* Il peso si riferisce alla sola pompa senza motorizzazione.  
\* The weight is referred to just the pump without the motor.

TABELLA RENDIMENTI PERFORMANCE CHART								
g/min R.P.M.	500		550		600		650	
BAR P.S.I.	L/min USGPM	KW HP	L/min USGPM	KW HP	L/min USGPM	KW HP	L/min USGPM	KW HP
2 29	20,8 5,5	0,09 0,1	22,8 6,0	0,10 0,1	24,9 6,6	0,11 0,1	27,0 7,1	0,12 0,2
10 145	19,6 5,2	0,4 0,6	21,6 5,7	0,5 0,6	23,5 6,2	0,5 0,7	25,5 6,7	0,6 0,9
15 217,5	19,2 5,1	0,6 0,9	21,1 5,6	0,7 0,9	23,0 6,1	0,8 1,0	24,9 6,6	0,8 1,1
20 290	18,5 4,9	0,8 1,1	20,3 5,4	0,9 1,2	22,2 5,9	1,0 1,3	24,0 6,3	1,1 1,4

Versioni Versions	Motore elettrico Electric motor	2025 h.p.
RTE.1	Monofase 1,5 KW Single-phase 1,5 KW	94.8660.97.ADS
	Trifase 1,5 KW Three-phase 1,5 KW	94.8661.97.ADS