

Strip Mini Poly Series

Poly 2020 h.p. RT4.1

22 l/m
5.8 USGPM

max 20 BAR
290 P.S.I.

APPLICAZIONI - APPLICATIONS

 AGRICOLTURA AGRICULTURE	 ORTICOLTURA HORTICULTURE	 CARRIOLE WHEELBARROWS
 GIARDINAGGIO GARDENING	 SERRE GREENHOUSES	 DISINFESTAZIONE DISINFESTATION

MEMBRANE - MEMBRANES

 VITON	 DESMOPAN	 BUNA
--	---	---

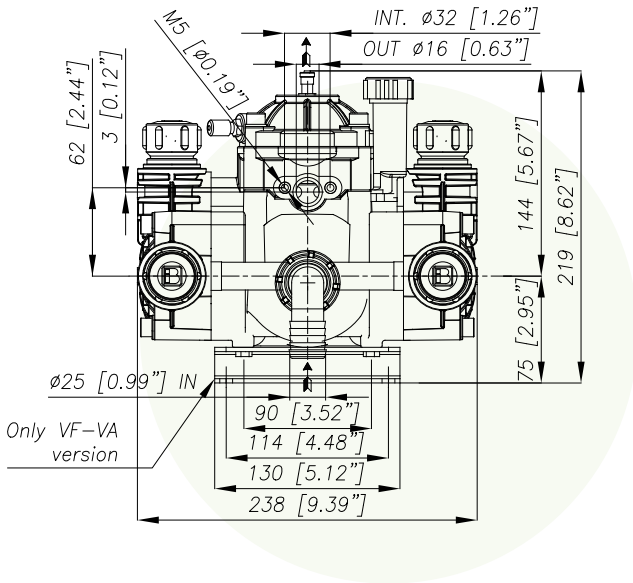

CARATTERISTICHE TECNICHE SPECIFICATIONS	650 g/min. 650 R.P.M.	
Potenza - Power	0,8 KW	1.1 HP
Peso* - Weight*	5,6 Kg	12.3 lb
IN	Ø 25 mm	Ø 1" in
Pressione Min - Min Pressure	-0,1 BAR	- 1.45 P.S.I.
Pressione Max - Max Pressure	1 BAR	14.5 P.S.I.
OUT	Predisposizione per accessori Prepared for accessories	
Max. Temperatura - Max. Temperature	60 °C	140 °F
Tipo olio - Oil type	SAE 30	
Capacità olio - Oil capacity	0,7 lt	0.18 U.S.G.

* Il peso si riferisce alla sola pompa senza motorizzazione.
* The weight is referred to just the pump without the motor.

TABELLA RENDIMENTI PERFORMANCE CHART								
g/min R.P.M.	500		550		600		650	
BAR P.S.I.	L/min USGPM	KW HP	L/min USGPM	KW HP	L/min USGPM	KW HP	L/min USGPM	KW HP
2 29	16,9 4,5	0,1 0,1	18,6 4,9	0,1 0,2	20,3 5,4	0,1 0,2	22,0 5,8	0,1 0,1
10 145	15,4 4,1	0,3 0,5	16,9 4,5	0,4 0,5	18,5 4,9	0,4 0,5	20,0 5,3	0,4 0,6
15 217,5	14,8 3,9	0,5 0,7	16,2 4,3	0,5 0,7	17,7 4,7	0,6 0,8	19,2 5,1	0,6 0,9
20 290	14,6 3,9	0,7 0,9	16,1 4,2	0,7 1,0	17,5 4,6	0,8 1,0	19,0 5,0	0,8 1,1

Versioni Versions	Motore Engine	2020 h.p.
RT4.1	AXO AMG 101 (4T-2 KW)	94.8562.97.ADS