

Power Unit CK 3006 PU CK 2010



189 l/m
50 USGPM



max 90 BAR
1305 P.S.I.

APPLICAZIONI - APPLICATIONS



ANTINCENDIO
FIRE PREVENTION



INSTALLAZIONI NAVALI
NAVAL INSTALLATIONS



PROCESSI INDUSTRIALI
INDUSTRIAL PROCESSES



INSTALLAZIONI AEREOPORTUALI
AIRPORT INSTALLATIONS

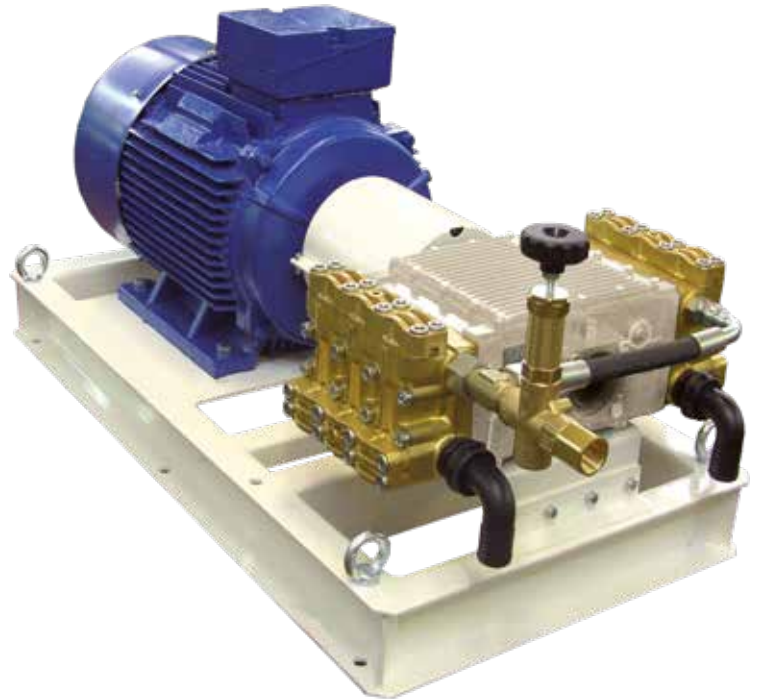
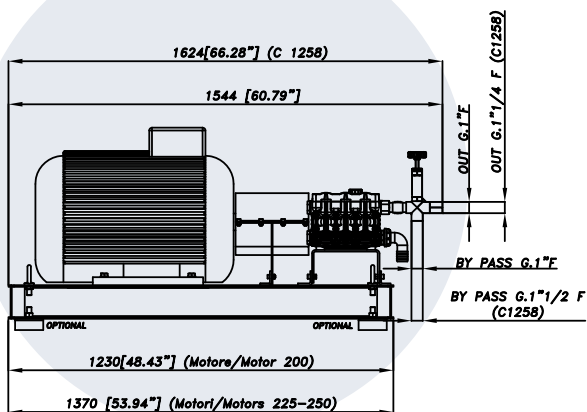
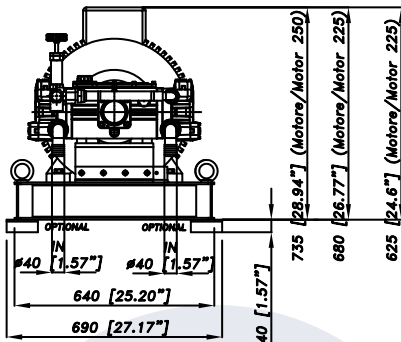

CARATTERISTICHE TECNICHE SPECIFICATIONS

Peso - Weight	70 Kg	154 lb
Misure - Size	1230 x 640 mm	48.43" x 25.20" in
	1370 x 640 mm	53.93" x 25.20" in
IN	1" 1/2 BSP (NR.2)	
Pressione Min - Min Pressure	-0,2 BAR	-3 P.S.I.
Pressione Max - Max Pressure	6 BAR	87 P.S.I.
OUT	1" BSP (NR.2)	
Valvola fuori - Valve out	1" BSP / 1"1/4 BSP (C1258)	
Valvola by-pass - Valve by-pass	1" BSP / 1"1/2 BSP (C1258)	
Max. Temperatura - Max. Temperature	60 °C	140 °F
Tipo olio - Oil type	SAE 75 - W 90	
Capacità olio - Oil capacity	2,8 lt	0.74 U.S.G.

Power Unit CK 3006
PU CK 2010



189 l/m
50 USGPM



max 90 BAR
1305 P.S.I.

TABELLA RENDIMENTI
PERFORMANCE CHART

CODICI CODES			POMPA PUMP	MOTORE TRIFASE THREE-PHASE MOTOR			RPM	PRESSIONE PRESSURE		PORTATA FLOW		PESO GRUPPO COMPLETE POWER UNIT WEIGHT	
GRUPPO ELETTROPOMPA POWER UNIT (A)	BASAMENTO BASE (B)	GRUPPO COMPLETO COMPLETE POWER UNIT (A+B)		50Hz - 400V	kW	A		BAR	P.S.I.	L/min	GPM	Kg	LBS
76.9105.97.3	73.9503.97.3	76.9205.97.3	CK 2010	225M 6 POLI	30	58,9	975	90	1305	189	50	475	1045
76.9106.97.3	73.9504.97.3	76.9206.97.3	CK 2580	250M 6 POLI	37	69,3	975	70	1015	243	64,3	591	1300