

PPS Series

PPS 550



54 l/m
14.3 USGPM



max 40 BAR
580 P.S.I.

APPLICAZIONI - APPLICATIONS



DISINFESTAZIONE
DISINFESTATION



ATOMIZZATORI
ATOMIZERS

MEMBRANE - MEMBRANES



DESMOPAN

DURAMAX

HPS

VITON

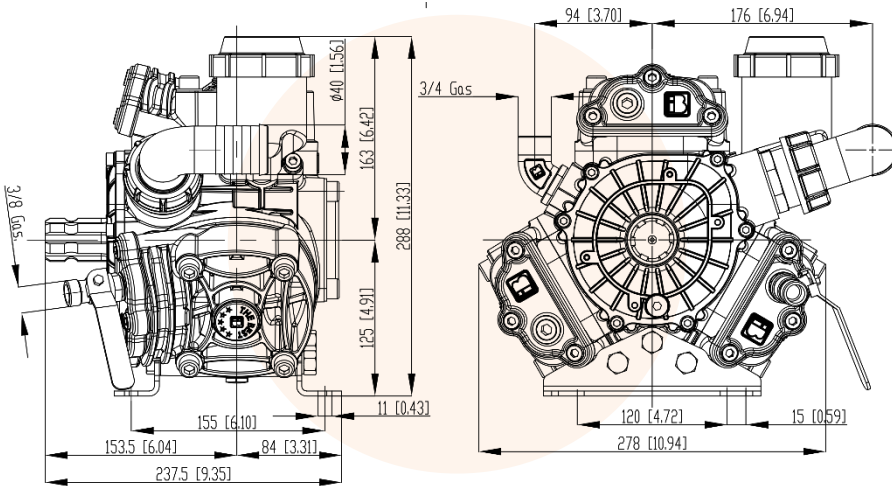

CARATTERISTICHE TECNICHE SPECIFICATIONS

550 g/min.
550 R.P.M.

Potenza - Power	4,0 KW	5.4 HP
Peso - Weight	15 Kg	33 lb
IN	Ø 40 mm	Ø 1"9/16 in
Pressione Min - Min Pressure	-0,15 BAR	- 2.17 P.S.I.
	-0,3 BAR (servizio discontinuo)	-0.435 P.S.I. (discontinuous service)
Pressione Max - Max Pressure	1 BAR	14.5 P.S.I.
OUT	G 3/4	
Max. Temperatura - Max. Temperature	60 °C	140 °F
Tipo olio - Oil type	SAE 30	
Capacità olio - Oil capacity	0,5 It	0.13 U.S.G.

TABELLA RENDIMENTI PERFORMANCE CHART

g/min R.P.M.	400		450		500		550	
BAR P.S.I.	L/min USGPM	KW HP	L/min USGPM	KW HP	L/min USGPM	KW HP	L/min USGPM	KW HP
2 29	39,3 10,4	0,2 0,3	44,2 11,7	0,2 0,3	49,1 13,0	0,2 0,3	54,0 14,3	0,2 0,3
20 290	37,8 10,0	1,5 2,0	42,5 11,2	1,7 2,2	47,3 12,5	1,9 2,5	52,0 13,7	2,0 2,7
30 435	37,5 9,9	2,2 2,9	42,1 11,1	2,5 3,3	46,8 12,4	2,8 3,7	51,5 13,6	3,0 4,1
40 580	37,1 9,8	2,9 3,9	41,7 11,0	3,3 4,4	46,4 12,2	3,6 4,9	51,0 13,5	4,0 5,4

Versioni/Versions

22.1000.97.3	POMPA PPS 550 MF
22.1001.97.3	POMPA PPS 550 VP
22.1002.97.3	POMPA PPS 550 VP1
22.1003.97.3	POMPA PPS 550 VC
22.1004.97.3	POMPA PPS 550 VI
22.1005.97.3	POMPA PPS 550 VS
22.1006.97.3	POMPA PPS 550 VS