

POLY Series POLY 550



54 l/m
14.3 USGPM



max 15 BAR
218 P.S.I.

APPLICAZIONI - APPLICATIONS



DISINFESTAZIONE
DISINFESTATION



ATOMIZZATORI
ATOMIZERS

MEMBRANE - MEMBRANES



DESMOPAN

DURAMAX

HPS

VITON

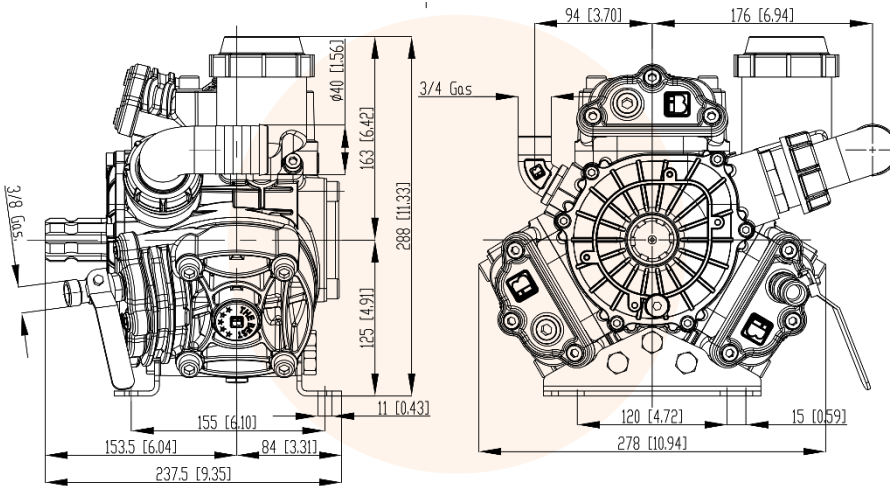

CARATTERISTICHE TECNICHE SPECIFICATIONS

550 g/min.
550 R.P.M.

Potenza - Power	1,5 KW	2 HP
Peso - Weight	15 Kg	33 lb
IN	Ø 40 mm	Ø 1"9/16 in
Pressione Min - Min Pressure	-0,15 BAR	- 2.17 P.S.I.
	-0,3 BAR (servizio discontinuo)	-0.435 P.S.I. (discontinuous service)
Pressione Max - Max Pressure	1,5 BAR	4.9 P.S.I.
OUT	G 3/4	
Max. Temperatura - Max. Temperature	60 °C	140 °F
Tipo olio - Oil type	SAE 30	
Capacità olio - Oil capacity	0,5 It	0.13 U.S.G.

TABELLA RENDIMENTI PERFORMANCE CHART

g/min R.P.M.	400		450		500		550	
BAR P.S.I.	L/min USGPM	KW HP	L/min USGPM	KW HP	L/min USGPM	KW HP	L/min USGPM	KW HP
2 29	39,3 10,4	0,2 0,2	44,2 11,7	0,2 0,2	49,1 13,0	0,2 0,3	54,0 14,3	0,2 0,3
20 290	37,8 10,0	0,4 0,5	42,5 11,2	0,4 0,6	47,3 12,5	0,5 0,6	52,0 13,7	0,5 0,7
30 435	37,5 9,9	0,7 1,0	42,1 11,1	0,8 1,1	46,8 12,4	0,9 1,2	51,5 13,6	1,0 1,1
40 580	37,1 9,8	1,1 1,5	41,7 11,0	1,2 1,6	46,4 12,2	1,4 1,8	51,0 13,5	1,5 2,0

Versioni/Versions

222000973	POMPA Poly 550 MF
222001973	POMPA Poly 550 VP
222002973	POMPA Poly 550 VP1
222003973	POMPA Poly 550 VC
222004973	POMPA Poly 550 VI
222005973	POMPA Poly 550 VS