

# PBO Series

## PBO 1840.1



179 l/m  
47.3 USGPM



max 50 BAR  
725 P.S.I.

### APPLICAZIONI - APPLICATIONS



DISINFESTAZIONE  
DISINFESTATION



ATOMIZZATORI  
ATOMIZERS

### MEMBRANE - MEMBRANES



DESMOPAN

DURAMAX

HPS

VITON

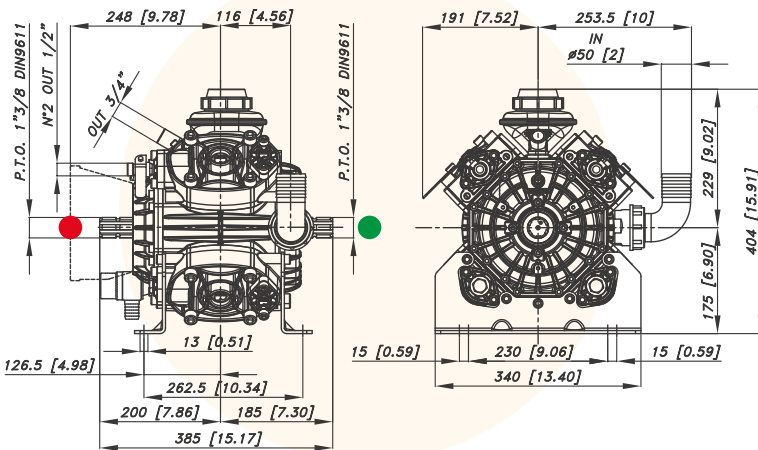

CARATTERISTICHE TECNICHE SPECIFICATIONS	550 g/min. 550 R.P.M.		TABELLA RENDIMENTI PERFORMANCE CHART								
	Potenza - Power	22.6 HP	g/min R.P.M.	400		450		500		550	
Peso - Weight	36 Kg	79 lb	BAR P.S.I.	L/min USGPM	KW HP	L/min USGPM	KW HP	L/min USGPM	KW HP	L/min USGPM	KW HP
IN	Ø 50 mm	Ø 2" in	2	130,2	0,5	146,5	0,6	162,7	0,6	179	0,7
Pressione Min - Min Pressure	-0,15 BAR	- 2.17 P.S.I.	29	34,4	0,7	38,7	0,8	43	0,9	47,3	0,9
Pressione Max - Max Pressure	1 BAR	14.5 P.S.I.	20	128,7	5,1	144,8	5,7	160,9	6,3	177	7,0
OUT	G 3/4		290	34	6,8	38,3	7,6	42,5	8,4	46,8	9,3
Max. Temperatura - Max. Temperature	60 °C	140 °F	40	126,5	9,9	142,4	11,2	158,2	12,4	174	13,7
Tipo olio - Oil type	SAE 30		580	33,4	13,3	37,6	14,9	41,8	16,6	46	18,3
Capacità olio - Oil capacity	1,25 lt	0.3 U.S.G.	50	125,1	12,3	140,7	13,8	156,4	15,4	172	16,9
			725	33	16,4	37,2	18,5	41,3	20,5	45,4	22,6

### Versioni Versions

