

# PBO Series

## PBO 1540.1

154 l/m  
40.7 USGPM

max 50 BAR  
725 P.S.I.

### APPLICAZIONI - APPLICATIONS



DISINFESTAZIONE  
DISINFESTATION



ATOMIZZATORI  
ATOMIZERS

### MEMBRANE - MEMBRANES



DESMOPAN

DURAMAX

HPS

VITON

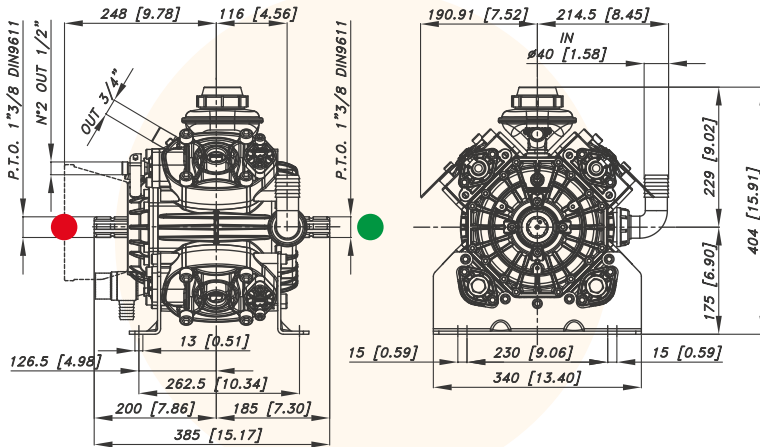

CARATTERISTICHE TECNICHE SPECIFICATIONS	550 g/min. 550 R.P.M.		TABELLA RENDIMENTI PERFORMANCE CHART								
	Potenza - Power	14,4 KW 19.3 HP	g/min R.P.M.	400		450		500		550	
Peso - Weight	36 Kg 79 lb		BAR P.S.I.	L/min USGPM	KW HP	L/min USGPM	KW HP	L/min USGPM	KW HP	L/min USGPM	KW HP
IN	Ø 40 mm Ø 1"9/16 in		2 29	112,0 29,6	0,4 0,6	126,0 33,3	0,5 0,7	140,0 37,0	0,5 0,7	154,0 40,7	0,6 0,8
Pressione Min - Min Pressure	-0,15 BAR -2.17 P.S.I.		20 290	109,1 28,8	4,3 5,7	122,7 32,4	4,8 6,4	136,4 36,0	5,4 7,2	150,0 39,6	5,9 7,9
Pressione Max - Max Pressure	1 BAR 14.5 P.S.I.		40 580	107,6 28,4	8,5 11,3	121,1 32,0	9,5 12,7	134,5 35,5	10,6 14,1	148,0 39,1	11,6 15,5
OUT	G 3/4		50 725	106,9 28,2	10,5 14,0	120,3 31,8	11,8 15,8	133,6 35,3	13,1 17,5	147,0 38,8	14,4 19,3
Max. Temperatura - Max. Temperature	60 °C 140 °F										
Tipo olio - Oil type	SAE 30										
Capacità olio - Oil capacity	1,25 lt 0.33 U.S.G.										

### Versioni Versions



Anteriore/Front

Posteriore/Rear

Anteriore/Front

Posteriore/Rear

Anteriore/Front

Posteriore/Rear

