

PBO Series

PBO 1100.1



110 l/m
29.1 USGPM



max 50 BAR
725 P.S.I.

APPLICAZIONI - APPLICATIONS



DISINFESTAZIONE
DISINFESTATION



ATOMIZZATORI
ATOMIZERS

MEMBRANE - MEMBRANES



DESMOPAN

DURAMAX

HPS

VITON

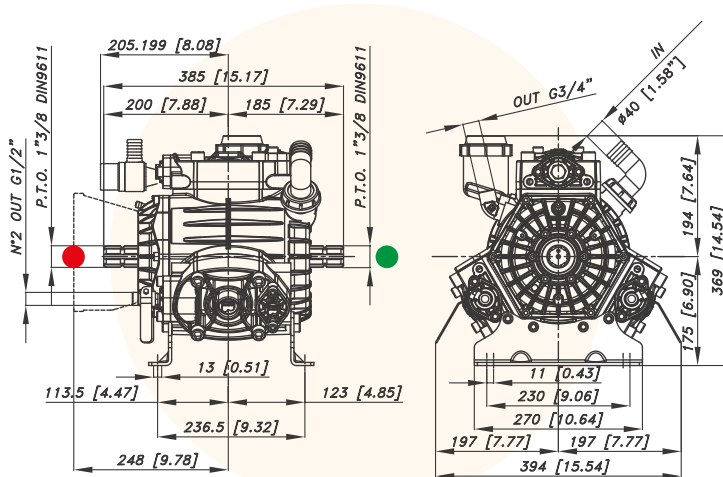

CARATTERISTICHE TECNICHE SPECIFICATIONS	550 g/min. 550 R.P.M.		TABELLA RENDIMENTI PERFORMANCE CHART								
	Potenza - Power	10,4 KW 13.9 HP	g/min R.P.M.	400		450		500		550	
Peso - Weight	25,3 Kg 55.6 lb		BAR P.S.I.	L/min USGPM	KW HP	L/min USGPM	KW HP	L/min USGPM	KW HP	L/min USGPM	KW HP
IN	Ø 40 mm Ø 1"9/6 in		2 29	80 21,1	0,3 0,4	90 23,8	0,4 0,5	100 26,4	0,4 0,5	110 29,1	0,4 0,6
Pressione Min - Min Pressure	-0,15 BAR - 2.17 P.S.I.		20 290	79 20,9	3,1 4,1	88,9 23,5	3,5 4,7	98,7 26,1	3,9 5,2	108,6 28,7	4,3 5,7
Pressione Max - Max Pressure	1 BAR 14.5 P.S.I.		40 580	77,9 20,6	6,1 8,2	87,6 23,2	6,9 9,2	97,4 25,7	7,6 10,2	107,1 28,3	8,4 11,2
OUT	G 3/4		50 725	77,1 20,4	7,6 10,1	86,7 22,9	8,5 11,4	96,4 25,5	9,5 12,6	106 28	10,4 13,9
Max. Temperatura - Max. Temperature	60 °C 140 °F										
Tipo olio - Oil type	SAE 30										
Capacità olio - Oil capacity	1 lt 0.26 U.S.G.										

Versioni Versions



Anteriore/Front Posteriore/Rear Anteriore/Front Posteriore/Rear Anteriore/Front Posteriore/Rear Posteriore/Rear

