

APPLICAZIONI - APPLICATIONS



DISINFESTAZIONE
DISINFESTATION



ATOMIZZATORI
ATOMIZERS

MEMBRANE - MEMBRANES



DESMOPAN

DURAMAX

HPS

VITON

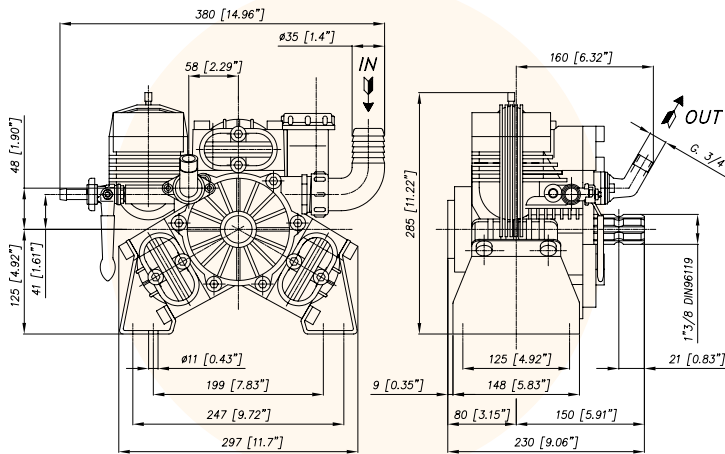

CARATTERISTICHE TECNICHE SPECIFICATIONS	550 g/min. 550 R.P.M.	
Potenza - Power	5,3 KW	7 HP
Peso* - Weight*	15 Kg	33 lb
IN	Ø 35 mm	Ø 1"3/8 in
Pressione Min - Min Pressure	-0,15 BAR	- 2.17 P.S.I.
	-0,3 BAR (servizio discontinuo)	-0.435 P.S.I. (discontinuous service)
Pressione Max - Max Pressure	1 BAR	14.5 P.S.I.
OUT	G 3/4	
Max. Temperatura - Max. Temperature	60 °C	140 °F
Tipo olio - Oil type	SAE 30	
Capacità olio - Oil capacity	0,5 lt	0.13 U.S.G.

* Il peso si riferisce alla sola pompa senza motorizzazione.
* The weight is referred to just the pump without the motor.

TABELLA RENDIMENTI PERFORMANCE CHART		400		450		500		550	
g/min R.P.M.	400	450	400	450	400	450	400	450	
BAR P.S.I.	L/min USGPM	KW HP	L/min USGPM	KW HP	L/min USGPM	KW HP	L/min USGPM	KW HP	
2 29	50,9 13,5	0,2 0,3	57,3 15,1	0,2 0,3	63,6 16,8	0,2 0,3	70 18,5	0,3 0,4	
20 290	50 13,2	2 2,6	56,3 14,9	2,2 3	62,5 16,5	2,5 3,3	68,8 18,2	2,7 3,6	
30 435	49,4 13	2,9 3,9	55,6 14,7	3,3 4,4	61,7 16,3	3,6 4,9	67,9 17,9	8,3 5,3	
40 580	48,8 12,9	3,8 5,1	54,9 14,5	4,3 5,8	61 16,1	4,8 6,4	67,1 17,7	5,3 7	

Versioni Versions	Motore termico Petrol engine	PA 730.1
VF	Subaru EX 27 (4T-6,6 KW)	23.8011.97.A