

PA Series PA 530

54 l/m
14.3 USGPM

max 40 BAR
580 P.S.I.

APPLICAZIONI - APPLICATIONS



DISINFESTAZIONE
DISINFESTATION



ATOMIZZATORI
ATOMIZERS

MEMBRANE - MEMBRANES



DESMOFAN

DURAMAX

HPS

VITON

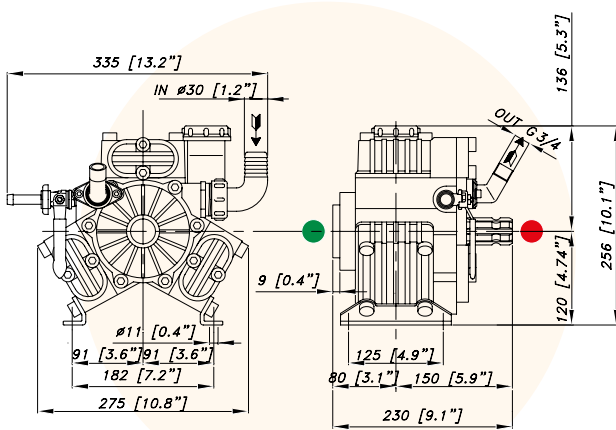

CARATTERISTICHE TECNICHE SPECIFICATIONS	550 g/min. 550 R.P.M.		TABELLA RENDIMENTI PERFORMANCE CHART								
	4,0 KW	5.4 HP	g/min R.P.M.	400		450		500		550	
Potenza - Power	4,0 KW	5.4 HP	BAR P.S.I.	L/min USGPM	KW HP	L/min USGPM	KW HP	L/min USGPM	KW HP	L/min USGPM	KW HP
Peso - Weight	14 Kg	31 lb	2	39,3	0,2	44,2	0,2	49,1	0,2	54,0	0,2
IN	\varnothing 30 mm	\varnothing 1"1/8 in	29	10,4	0,3	11,7	0,3	13,0	0,3	14,3	0,3
Pressione Min - Min Pressure	-0,15 BAR	- 2.17 P.S.I.	20	37,8	1,5	42,5	1,7	47,3	1,9	52,0	2,0
Pressione Max - Max Pressure	1 BAR	14.5 P.S.I.	290	10,0	2,0	11,2	2,2	12,5	2,5	13,7	2,7
OUT	G 3/4		30	37,5	2,2	42,1	2,5	46,8	2,8	51,5	3,0
Max. Temperatura - Max. Temperature	60 °C	140 °F	435	9,9	2,9	11,1	3,3	12,4	3,7	13,6	4,1
Tipo olio - Oil type	SAE 30		40	37,1	2,9	41,7	3,3	46,4	3,6	51,0	4,0
Capacità olio - Oil capacity	0,5 lt	0.13 U.S.G.	580	9,8	3,9	11,0	4,4	12,2	4,9	13,5	5,4

Versioni Versions

