

PA Series

PA 430.1 VF



40 L/m
10.6 USGPM



max 40 BAR
580 P.S.I.

APPLICAZIONI - APPLICATIONS



DISINFESTAZIONE
DISINFESTATION



ATOMIZZATORI
ATOMIZERS

MEMBRANE - MEMBRANES



DESMOPAN
DURAMAX
HPS

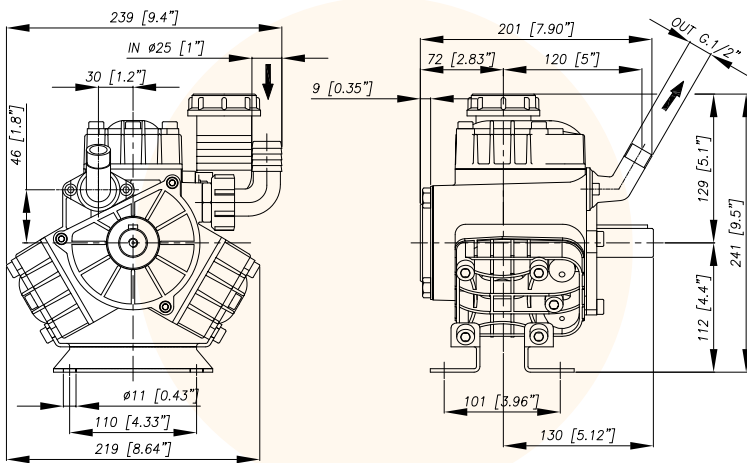

CARATTERISTICHE TECNICHE SPECIFICATIONS	650 g/min. 650 R.P.M.	
Potenza - Power	2,8 KW	3.8 HP
Peso* - Weight*	7,8 Kg	17 lb
IN	$\varnothing 25$ mm	$\varnothing 1$ "in
Pressione Min - Min Pressure	-0,15 BAR	- 2.17 P.S.I.
Pressione Max - Max Pressure	1 BAR	14.5 P.S.I.
OUT	G 1/2	
Max. Temperatura - Max. Temperature	60 °C	140 °F
Tipo olio - Oil type	SAE 30	
Capacità olio - Oil capacity	0,6 lt	0.16 U.S.G.

TABELLA RENDIMENTI PERFORMANCE CHART								
g/min R.P.M.	500		550		600		650	
BAR P.S.I.	L/min USGPM	KW HP	L/min USGPM	KW HP	L/min USGPM	KW HP	L/min USGPM	KW HP
2 29	30,8 8,1	0,1 0,2	33,8 8,9	0,1 0,2	36,9 9,8	0,1 0,2	40,0 10,6	0,1 0,2
20 290	28,5 7,5	1,1 1,5	31,3 8,3	1,2 1,6	34,2 9,0	1,3 1,8	37,0 9,8	1,5 1,9
30 435	28,1 7,4	1,7 2,2	30,9 8,2	1,8 2,4	33,7 8,9	2,0 2,7	36,5 9,6	2,2 2,9
40 580	27,7 7,3	2,2 2,9	30,5 8,0	2,4 3,2	33,2 8,8	2,6 3,5	36,0 9,5	2,8 3,8

* Il peso si riferisce alla sola pompa senza motorizzazione.
* The weight is referred to just the pump without the motor.

Versioni Versions	Motore termico Petrol engine	PA 430.1
VF	Subaru SP 17 (4T-4,0 KW)	03.8018.97.A
	AXO AMG 210 (4T-4,0 KW)	03.8021.97.B
	Kohler SH 265 (4T-4,5 KW)	03.8022.97.A