

PA Series PA 430.1

40 l/m
10.6 USGPM

max 40 BAR
580 P.S.I.

APPLICAZIONI - APPLICATIONS



DISINFESTAZIONE
DISINFESTATION



ATOMIZZATORI
ATOMIZERS

MEMBRANE - MEMBRANES



DESMOFAN

DURAMAX

HPS

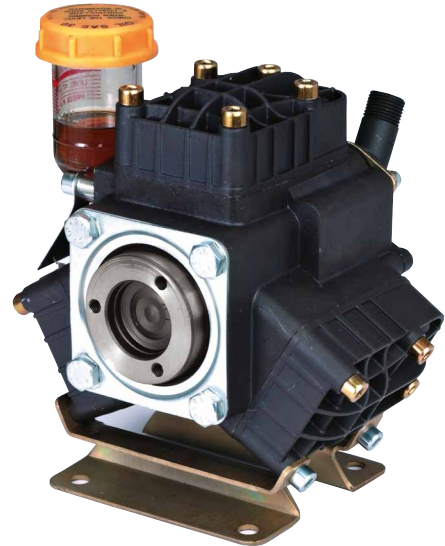
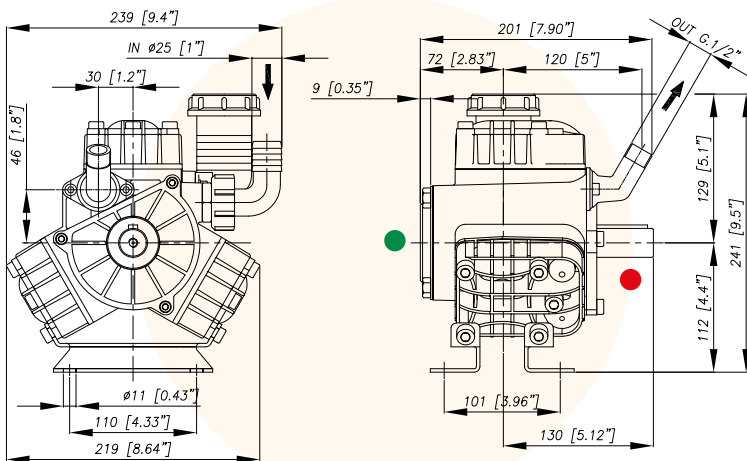

CARATTERISTICHE TECNICHE SPECIFICATIONS	650 g/min. 650 R.P.M.		TABELLA RENDIMENTI PERFORMANCE CHART									
	Potenza - Power	2,8 KW	3.8 HP	g/min R.P.M.	500		550		600		650	
Peso - Weight	7,8 Kg	17 lb		BAR P.S.I.	L/min USGPM	KW HP	L/min USGPM	KW HP	L/min USGPM	KW HP	L/min USGPM	KW HP
IN	Ø 25 mm	Ø 1" in		2 29	30,8 8,1	0,1 0,2	33,8 8,9	0,1 0,2	36,9 9,8	0,1 0,2	40,0 10,6	0,1 0,2
Pressione Min - Min Pressure	-0,15 BAR	- 2.17 P.S.I.		20 290	28,5 7,5	1,1 1,5	31,3 8,3	1,2 1,6	34,2 9,0	1,3 1,8	37,0 9,8	1,5 1,9
Pressione Max - Max Pressure	1 BAR	14.5 P.S.I.		30 435	28,1 7,4	1,7 2,2	30,9 8,2	1,8 2,4	33,7 8,9	2,0 2,7	36,5 9,6	2,2 2,9
OUT	G 1/2			40 580	27,7 7,3	2,2 2,9	30,5 8,0	2,4 3,2	33,2 8,8	2,6 3,5	36,0 9,5	2,8 3,8
Max. Temperatura - Max. Temperature	60 °C	140 °F										
Tipo olio - Oil type	SAE 30											
Capacità olio - Oil capacity	0,6 lt	0.16 U.S.G.										

Versioni Versions

03.7007.97.3 - VF

03.7012.97.3-VF (900 R.P.M.)



Posteriore/Rear

Posteriore/Rear

Anteriore/Front