

IDB Series

IDB 1600

162 l/m
42.8 USGPM

max 50 BAR
725 P.S.I.

APPLICAZIONI - APPLICATIONS

ATOMIZZATORI
ATOMIZERS

MEMBRANE - MEMBRANES

D
DS
H
V
 DESMOFAN
 DURAMAX
 HPS
 VITON

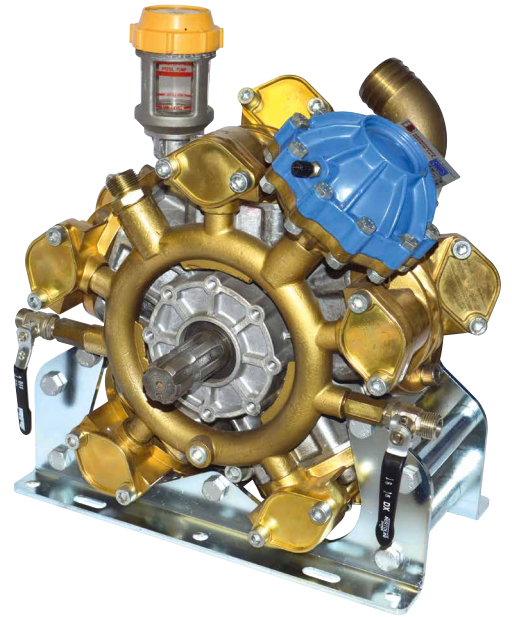
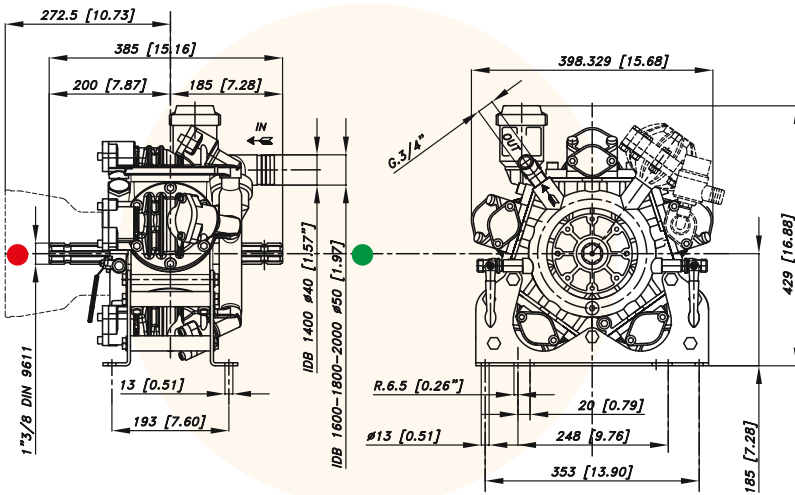

CARATTERISTICHE TECNICHE SPECIFICATIONS	550 g/min. 550 R.P.M.	
Potenza - Power	15,1 KW	20.2 HP
Peso - Weight	58 Kg	127,8 lb
IN	50 mm	2" in
Pressione Min - Min Pressure	-0,15 BAR	- 2.17 P.S.I.
	-0,3 BAR (servizio discontinuo)	-0.435 P.S.I. (discontinuous service)
Pressione Max - Max Pressure	1 BAR	14.5 P.S.I.
OUT	G 3/4	
Max. Temperatura - Max. Temperature	60 °C	140 °F
Tipo olio - Oil type	SAE 30	
Capacità olio - Oil capacity	2,52 lt	0.66 U.S.G.

TABELLA RENDIMENTI PERFORMANCE CHART								
g/min R.P.M.	400		450		500		550	
BAR P.S.I.	L/min USGPM	KW HP	L/min USGPM	KW HP	L/min USGPM	KW HP	L/min USGPM	KW HP
2 29	118 31,1	0,5 0,6	133 35,0	0,5 0,7	147 38,9	0,6 0,8	162 42,8	0,6 0,9
20 290	116 30,6	4,5 6,1	130 34,4	5,1 6,8	145 38,2	5,7 7,6	159 42,0	6,2 8,3
40 580	113 30,0	8,9 11,9	128 33,7	10,0 13,4	142 37,5	11,1 14,9	156 41,2	12,3 16,4
50 725	112 29,6	11,0 14,7	126 33,3	12,4 16,5	140 37,0	13,7 18,4	154 40,7	15,1 20,2

Versioni Versions

49.6010.97.A - VD

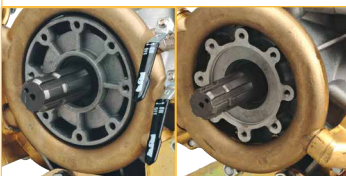

Anteriore/Front Posteriore/Rear



IDB Series

BERTOLINI
pumps