

COMPACT Series

C 53.3

50.6 l/m
13.4 USGPM

max 50 BAR
725 P.S.I.

APPLICAZIONI - APPLICATIONS



ATOMIZZATORI
ATOMIZERS



CLEANING
CLEANING



NEBULIZZAZIONE
SPRAYING

SPECIAL TRADEMARK



EASylube™



SUPERCOOLINGsystem™



SMARTcase™

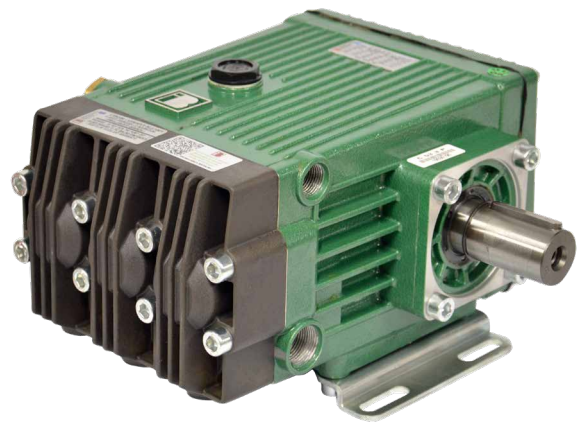
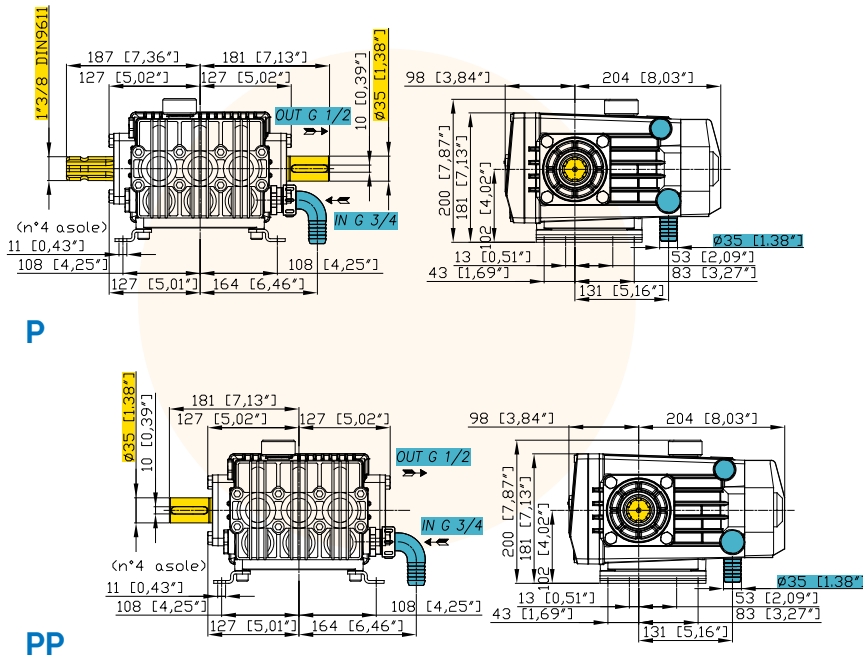

CARATTERISTICHE TECNICHE SPECIFICATIONS

550 g/min.
550 R.P.M.

Potenza - Power	4,9 KW	6.6 HP
Peso - Weight	20 Kg	44 lb
IN	25 mm	1" in
Pressione Min - Min Pressure	-0,15 BAR	- 2.17 P.S.I.
	-0,3 BAR (servizio discontinuo)	-0.435 P.S.I. (discontinuous service)
Pressione Max - Max Pressure	1 BAR	14.5 P.S.I.
OUT	G 1/2	
Max. Temperatura - Max. Temperature	60 °C	140 °F
Tipo olio - Oil type	SAE 30	
Capacità olio - Oil capacity	1,9 lt	0.5 U.S.G.

TABELLA RENDIMENTI PERFORMANCE CHART

g/min R.P.M.	400		450		500		550	
	BAR P.S.I.	L/min USGPM	KW HP	L/min USGPM	KW HP	L/min USGPM	KW HP	L/min USGPM
2 29	36,8	0,1	41,4	0,1	46,0	0,1	50,6	0,2
	9,7	0,2	10,9	0,2	12,2	0,2	13,4	0,3
30 435	36,7	2,2	41,2	2,4	45,8	2,7	50,4	3,0
	9,7	2,9	10,9	3,2	12,1	3,6	13,3	4,0
40 580	36,5	2,9	41,1	3,2	45,6	3,6	50,2	3,9
	9,6	3,8	10,9	4,3	12,1	4,8	13,3	5,3
50 725	36,4	3,6	40,9	4,0	45,5	4,5	50,0	4,9
	9,6	4,8	10,8	5,4	12,0	6,0	13,2	6,6

Versioni Versions

53.6000.97.A - P

53.6004.97.A - PP



Destro/Right

Sinistro/Left

Sinistro/Left