

# COMPACT Series C 40.1 STD

40.5 l/m  
10.7 USGPM

max 50 BAR  
725 P.S.I.

## APPLICAZIONI - APPLICATIONS



ATOMIZZATORI  
ATOMIZERS



CLEANING  
CLEANING



NEBULIZZAZIONE  
SPRAYING

## SPECIAL TRADEMARK

El EASYlube™

Sc SMARTcase™

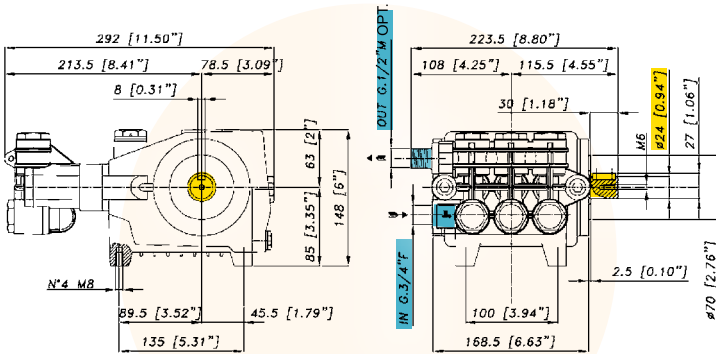

### CARATTERISTICHE TECNICHE SPECIFICATIONS

1450 g/min.  
1450 R.P.M.

<b>Potenza - Power</b>	<b>3,8 KW</b>	5.1 HP
<b>Peso* - Weight*</b>	<b>12 Kg</b>	24.6 lb
<b>IN</b>	<b>G 1/2</b>	
<b>Pressione Min - Min Pressure</b>	<b>-0,15 BAR</b>	- 2.17 P.S.I.
	<b>-0,3 BAR (servizio discontinuo)</b>	-0.435 P.S.I. (discontinuous service)
<b>Pressione Max - Max Pressure</b>	<b>1 BAR</b>	14.5 P.S.I.
<b>OUT</b>	<b>G 1/2</b>	
<b>Max. Temperatura - Max. Temperature</b>	<b>60 °C</b>	140 °F
<b>Tipo olio - Oil type</b>	<b>SAE 30</b>	
<b>Capacità olio - Oil capacity</b>	<b>0,95 lt</b>	0.25 U.S.G.

\* Il peso si riferisce alla sola pompa senza motorizzazione.  
\* The weight is referred to just the pump without the motor.

### TABELLA RENDIMENTI PERFORMANCE CHART

g/min R.P.M.	800		1000		1200		1450		
	BAR P.S.I.	L/min USGPM	KW HP	L/min USGPM	KW HP	L/min USGPM	KW HP	L/min USGPM	KW HP
2 29		22,3 5,9	0,1 0,1	27,9 7,4	0,1 0,1	33,5 8,9	0,1 0,2	40,5 10,7	0,2 0,2
20 290		22,1 5,8	1,3 1,7	27,6 7,3	1,6 2,2	33,1 8,7	2,0 2,6	40,0 10,6	2,4 3,1
40 580		21,8 5,8	1,7 2,3	27,2 7,2	2,1 2,9	32,7 8,6	2,6 3,4	39,5 10,4	3,1 4,1
50 725		21,5 5,7	2,1 2,8	26,9 7,1	2,6 3,5	32,3 8,5	3,2 4,2	39,0 10,3	3,8 5,1

Versioni Versions	Motore termico Petrol engine	C 40.1
STD	AXO AMG 210 (4T-4,0 KW)	38.8601.97.B
	Subaru SP 17 (4T-4,0 KW)	38.8602.97.A