

COMPACT Series

C 40.1



40.5 l/m
10.7 USGPM



max 50 BAR
725 P.S.I.

APPLICAZIONI - APPLICATIONS



ATOMIZZATORI
ATOMIZERS



CLEANING
CLEANING



NEBULIZZAZIONE
SPRAYING

SPECIAL TRADEMARK



EASYlube™



SMARTcase™

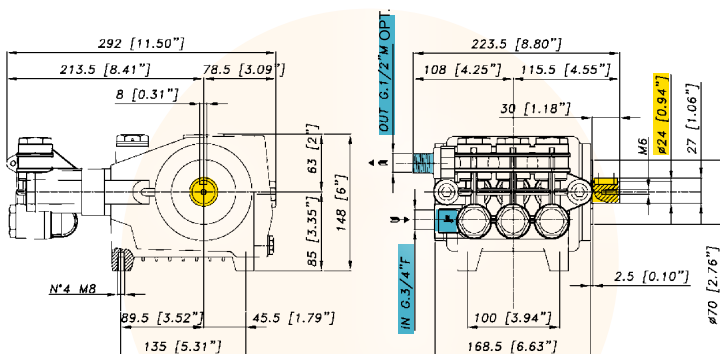

P

CARATTERISTICHE TECNICHE SPECIFICATIONS	1450 g/min. 1450 R.P.M.	
Potenza - Power	3,8 KW	5.1 HP
Peso - Weight	12 Kg	24,6 lb
IN	G 1/2	
Pressione Min - Min Pressure	-0,15 BAR	- 2.17 P.S.I.
	-0,3 BAR (servizio discontinuo)	-0.435 P.S.I. (discontinuous service)
Pressione Max - Max Pressure	1 BAR	14.5 P.S.I.
OUT	G 1/2	
Max. Temperatura - Max. Temperature	60 °C	140 °F
Tipo olio - Oil type	SAE 30	
Capacità olio - Oil capacity	0,95 lt	0.25 U.S.G.

TABELLA RENDIMENTI PERFORMANCE CHART								
g/min R.P.M.	800		1000		1200		1450	
BAR P.S.I.	L/min USGPM	KW HP	L/min USGPM	KW HP	L/min USGPM	KW HP	L/min USGPM	KW HP
2 29	22,3 5,9	0,1 0,1	27,9 7,4	0,1 0,1	33,5 8,9	0,1 0,2	40,5 10,7	0,2 0,2
20 290	22,1 5,8	1,3 1,7	27,6 7,3	1,6 2,2	33,1 8,7	2,0 2,6	40,0 10,6	2,4 3,1
40 580	21,8 5,8	1,7 2,3	27,2 7,2	2,1 2,9	32,7 8,6	2,6 3,4	39,5 10,4	3,1 4,1
50 725	21,5 5,7	2,1 2,8	26,9 7,1	2,6 3,5	32,3 8,5	3,2 4,2	39,0 10,3	3,8 5,1

Versioni Versions

38.9906.97.3

