

CX Series

CX 130

144 l/m
38 USGPM

max 70 BAR
1015 P.S.I.

APPLICAZIONI - APPLICATIONS

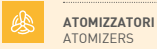

ATOMIZZATORI
ATOMIZERS



CLEANING
CLEANING

SPECIAL TRADEMARK

EL EASYtube™

Is INTELLiseal™

Sc SMARTcase™

LTr LIFETIMErod™

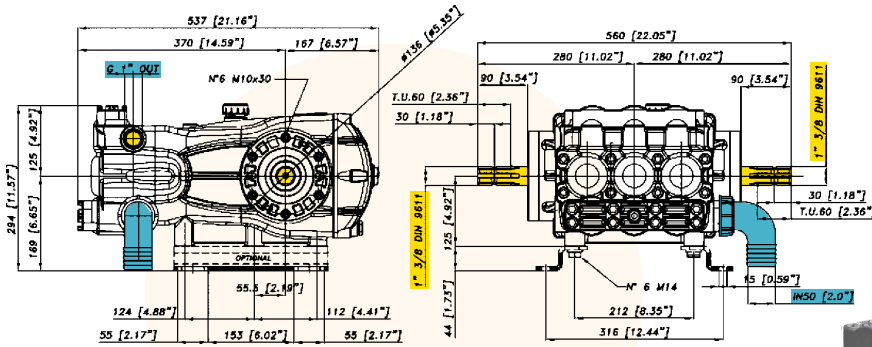

P



CARATTERISTICHE TECNICHE SPECIFICATIONS	550 g/min. 550 R.P.M.	
Potenza - Power	19,1 KW	25.5 HP
Peso - Weight	55 Kg	121 lb
IN	50 mm	2" in
Pressione Min - Min Pressure	-0,15 BAR	- 2.17 P.S.I.
	-0,3 BAR (servizio discontinuo)	-0.435 P.S.I. (discontinuous service)
Pressione Max - Max Pressure	1 BAR	14.5 P.S.I.
OUT	G 1	
Max. Temperatura - Max. Temperature	60 °C	140 °F
Tipo olio - Oil type	SAE 30	
Capacità olio - Oil capacity	6 lt	1.58 U.S.G.

TABELLA RENDIMENTI PERFORMANCE CHART								
g/min R.P.M.	400		450		500		550	
BAR P.S.I.	L/min USGPM	KW HP	L/min USGPM	KW HP	L/min USGPM	KW HP	L/min USGPM	KW HP
2 29	104,7 27,7	0,4 0,5	117,8 31,1	0,5 0,6	130,9 34,6	0,5 0,7	144,0 38,0	0,6 0,8
30 435	103,6 27,4	6,1 8,2	116,6 30,8	6,9 9,2	129,5 34,2	7,6 10,2	142,5 37,6	8,4 11,2
50 725	102,9 27,2	10,1 13,5	115,8 30,6	11,4 15,2	128,6 34,0	12,6 16,9	141,5 37,4	13,9 18,6
70 1015	101,1 26,7	13,9 18,6	113,7 30,0	15,6 20,9	126,4 33,4	17,4 23,2	139,0 36,7	19,1 25,5

Versioni Versions

74.1009.97.3 - P

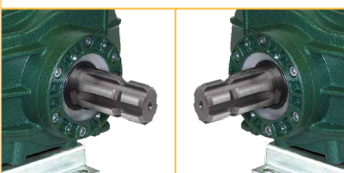

Destro/Right

Sinistro/Left