

# CR Series

## CR 8010



79 l/m  
20.9 USGPM



max 100 BAR  
1450 P.S.I.

### APPLICAZIONI - APPLICATIONS



**ANTINCENDIO**  
FIRE PREVENTION



**AUTOLAVAGGIO**  
CARWASH



**SPURGO**  
PURGING



**EDILIZIA**  
CONSTRUCTION



**PROCESSI INDUSTRIALI**  
INDUSTRIAL PROCESSES



**PULIZIA STRADALE**  
STREET CLEANING

### TECHNICAL PLUS:



**USCITA ALBERO DX**  
RIGHT DRIVE SHAFT



**BIELLE IN BRONZO**  
BRONZE CONRODS



**PISTONE IN CERAMICA DI GRANDE SPESSORE**  
PER ACQUA CALDA  
REVERSIBLE CRONKCASE FOR THE LEFT OR RIGHT HANDED



**GUARNIZIONI TENUTA ACQUA NBR (BUNA)**  
NBR (BUNA) WATER SEALS

### OPTIONAL:



**USCITA ALBERO LATO SX**  
LEFT DRIVE SHAFT



**KIT PIEDINI IN LAMIERA D'ACCIAIO ZINCATI**  
GALVANIZED STEEL MOUNTING RAILS KIT

### GUARNIZIONI - SEALS



**GUARNIZIONI ANT.SUPER "U"**  
POST. "U" (PTFE)  
SUPER "U" FRONT SEALS  
PTFE "U" BACK SEALS

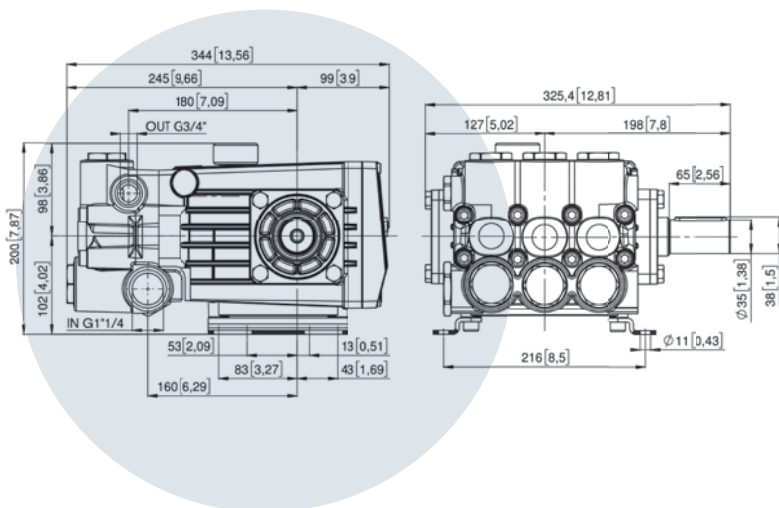

### CARATTERISTICHE TECNICHE

#### SPECIFICATIONS

<b>Peso - Weight</b>	<b>25 Kg</b>	55 lb
<b>IN</b>	<b>1"1/4 BSP</b>	
<b>Pressione Min - Min Pressure</b>	<b>-0,1 BAR</b>	-1.5 P.S.I.
<b>Pressione Max - Max Pressure</b>	<b>6 BAR</b>	87 P.S.I.
<b>OUT</b>	<b>3/4 BSP</b>	
<b>Albero - Shaft</b>	<b>Ø 35 mm</b>	
<b>Max. Temperatura - Max. Temperature</b>	<b>60 °C</b>	140 °F
<b>Tipo olio - Oil type</b>	<b>SAE 75 - W 90</b>	
<b>Capacità olio - Oil capacity</b>	<b>1,69 lt</b>	0.4 U.S.G.

# CR Series

## CR 8010



79 L/m  
20.9 USGPM



max 100 BAR  
1450 P.S.I.

TABELLA RENDIMENTI  
PERFORMANCE CHART

CODICE CODE	MODELLO MODEL	Press Max Max Pres.		RPM 950				RPM 1200				RPM 1450				Pist. Plung	Corsa Stroke
		BAR	P.S.I.	L/min	GPM	kW	HP	L/min	GPM	kW	HP	L/min	GPM	kW	HP		
53.5000.97.3	CR 8010	100	1450	53	14,0	10,3	14,0	66	17,4	13,0	17,7	79	20,9	15,4	20,9	30	28
53.5001.97.3	CR 1010	100	1450	64	16,9	12,5	17,0	81	21,4	15,8	21,5	96	25,4	18,7	25,4	30	34
53.5002.97.3	CR 1310	100	1450	84	22,2	16,6	22,5	106	28,0	20,9	28,5	129	34,1	25,3	34,4	32	40

GRAFICO PRESTAZIONI  
PERFORMANCE CHART

