

CHX Series

CHX M 24-1000

25 l/m
6.6 USGPM

max 1000 BAR
14500 P.S.I.

APPLICAZIONI - APPLICATIONS



ATOMIZZATORI
ATOMIZERS



CLEANING
CLEANING

SPECIAL TRADEMARK

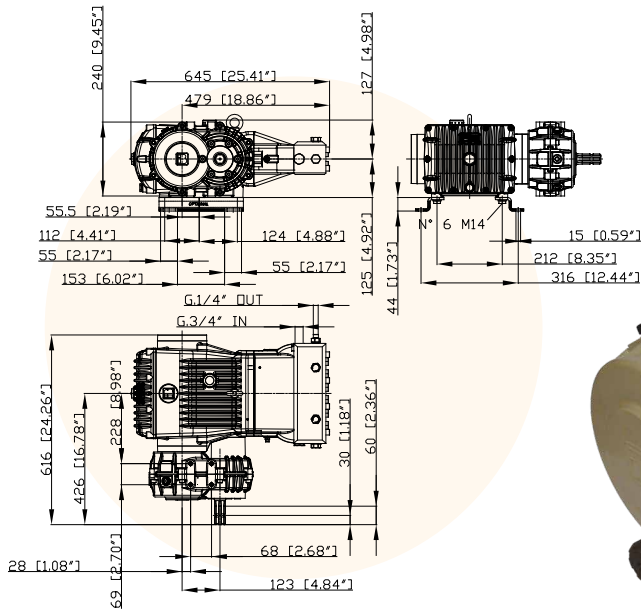

CARATTERISTICHE TECNICHE SPECIFICATIONS	550 g/min. 550 R.P.M.	
Potenza - Power	48,7 KW	65.1 HP
Peso - Weight	110 Kg	242 lb
IN	G 3/4	
Pressione Min - Min Pressure	-0,15 BAR -0,3 BAR (servizio discontinuo)	- 2.17 P.S.I. -0.435 P.S.I. (discontinuous service)
Pressione Max - Max Pressure	1 BAR	14.5 P.S.I.
OUT	G 1/4	
Max. Temperatura - Max. Temperature	60 °C	140 °F
Tipo olio - Oil type	SAE 75 - W90	
Capacità olio - Oil capacity	4 lt	1.05 U.S.G.

TABELLA RENDIMENTI PERFORMANCE CHART								
g/min R.P.M.	400		450		500		550	
BAR P.S.I.	L/min USGPM	KW HP	L/min USGPM	KW HP	L/min USGPM	KW HP	L/min USGPM	KW HP
800 11600	18,2 4,8	28,6 38,2	20,5 5,4	32,1 42,9	22,7 6,0	35,7 47,7	25,0 6,6	39,3 52,5
900 13050	18,1 4,8	32,0 42,8	20,4 5,4	36,0 48,1	22,6 6,0	40,0 53,4	24,9 6,6	44,0 58,8
1000 14500	18,0 4,8	35,4 47,3	20,3 5,4	39,8 53,2	22,5 6,0	44,3 59,1	24,8 6,6	48,7 65,1

Versioni Versions

74.1040.97.3



Destro/Right

Sinistro/Left

CHX Series

BERTOLINI
pumps