

CHX Series

CHX 24-1000

19 l/m
5 USGPM



max 1000 BAR
14500 P.S.I.

APPLICAZIONI - APPLICATIONS



ATOMIZZATORI
ATOMIZERS



CLEANING
CLEANING

SPECIAL TRADEMARK

EL EASYlube™

Is INTELLIseal™

Sc SMARTcase™

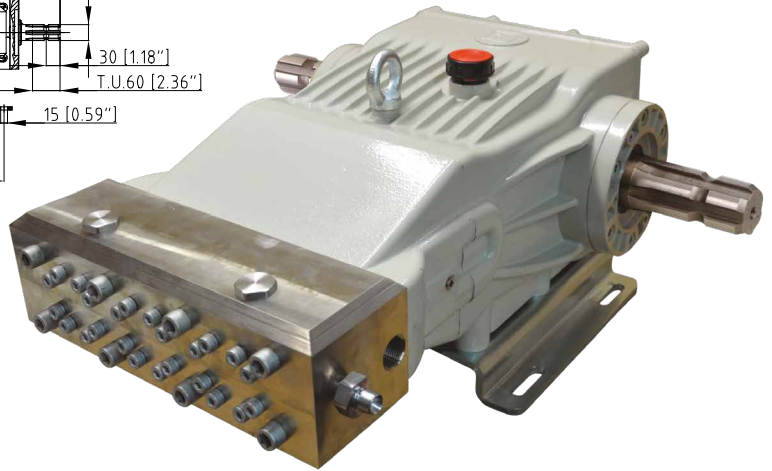
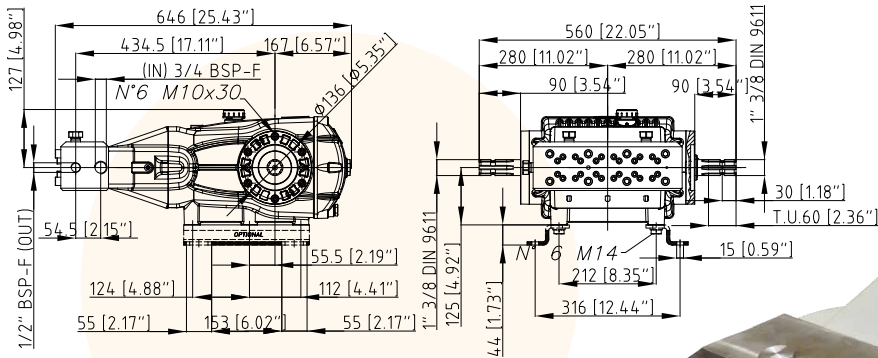

CARATTERISTICHE TECNICHE SPECIFICATIONS	550 g/min. 550 R.P.M.		TABELLA RENDIMENTI PERFORMANCE CHART						
Potenza - Power	36,9 KW	49.3 HP	g/min R.P.M.	550	650		750		
Peso - Weight	91 Kg	200.6 lb			BAR P.S.I.	L/min USGPM	KW HP	L/min USGPM	KW HP
IN	G 3/4								
Pressione Min - Min Pressure	-0,15 BAR	- 2.17 P.S.I.	800 11600	13,9 3,7	21,9 29,2	16,5 4,4	25,9 34,6	19,0 5,0	29,8 39,9
	-0,3 BAR (servizio discontinuo)	-0.435 P.S.I. (discontinuous service)	900 13050	13,9 3,7	24,5 32,7	16,4 4,3	28,9 38,7	18,9 5,0	33,4 44,6
Pressione Max - Max Pressure	1 BAR	14.5 P.S.I.	1000 14500	13,8 3,6	27,1 36,2	16,3 4,3	32,0 42,7	18,8 5,0	36,9 49,3
OUT	G 1/4								
Max. Temperatura - Max. Temperature	60 °C	140 °F							
Tipo olio - Oil type	SAE 75 - W90								
Capacità olio - Oil capacity	4 lt	1.05 U.S.G.							

Versioni Versions

74.1036.97.3



Destro/Right

Sinistro/Left