

CHX Series

CHX 13-1000

19 L/m
5 USGPM



max 1000 BAR
14500 P.S.I.

APPLICAZIONI - APPLICATIONS



ATOMIZZATORI
ATOMIZERS



CLEANING
CLEANING

SPECIAL TRADEMARK

EL EASYlube™

IS INTELLIseal™

Sc SMARTcase™

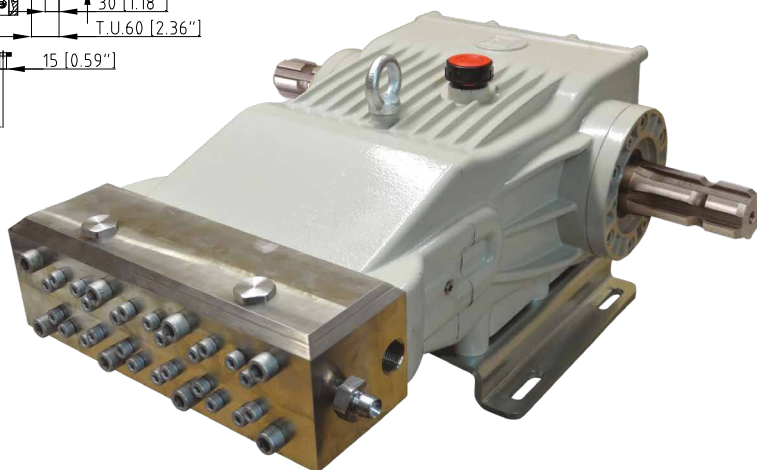
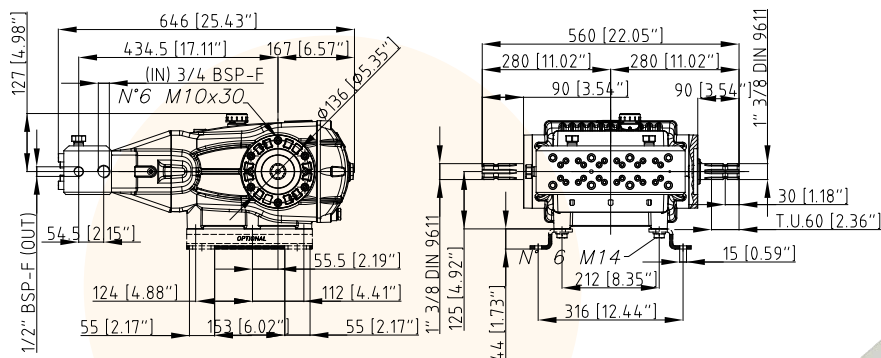

CARATTERISTICHE TECNICHE SPECIFICATIONS	550 g/min. 550 R.P.M.	
Potenza - Power	33,0 KW	44.1 HP
Peso - Weight	91 Kg	200.6 lb
IN	G 3/4	
Pressione Min - Min Pressure	-0,15 BAR	- 2.17 P.S.I.
	-0,3 BAR (servizio discontinuo)	-0.435 P.S.I. (discontinuous service)
Pressione Max - Max Pressure	1 BAR	14.5 P.S.I.
OUT	G 1/4	
Max. Temperatura - Max. Temperature	60 °C	140 °F
Tipo olio - Oil type	SAE 75 - W90	
Capacità olio - Oil capacity	4 lt	1.05 U.S.G.

TABELLA RENDIMENTI PERFORMANCE CHART						
g/min R.P.M.	550		650		750	
BAR P.S.I.	L/min USGPM	KW HP	L/min USGPM	KW HP	L/min USGPM	KW HP
800 11600	12,5 3,3	19,6 26,2	14,7 3,9	23,1 30,9	17,0 4,5	26,7 35,7
900 13050	12,4 3,3	21,9 29,3	14,6 3,9	25,9 34,6	16,9 4,5	29,9 39,9
1000 14500	12,3 3,3	24,2 32,3	14,6 3,8	28,6 38,2	16,8 4,4	33,0 44,1

Versioni Versions

74.1035.97.3



Destro/Right

Sinistro/Left