





COMPACT Series C 40.1 STD

	40.5 l/m 10.7 USGPM		max 50 BAR 725 P.S.I.
---	------------------------	---	--------------------------

APPLICAZIONI - APPLICATIONS

	ATOMIZZATORI ATOMIZERS		CLEANING CLEANING
	NEBULIZZAZIONE SPRAYING		

SPECIAL TRADEMARK

	EASYlube™
	SMARTcase™

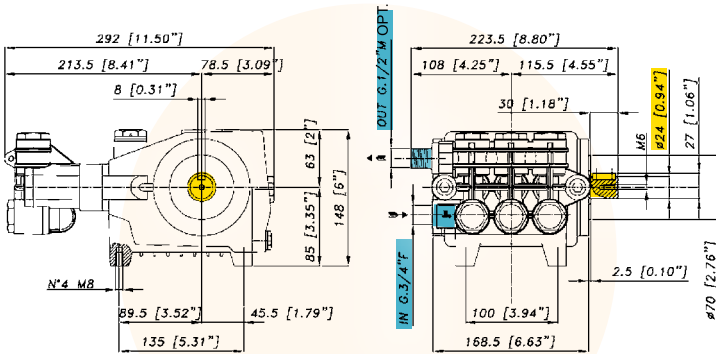

CARATTERISTICHE TECNICHE SPECIFICATIONS	1450 g/min. 1450 R.P.M.	
Potenza - Power	3,8 KW	5.1 HP
Peso - Weight	12 Kg	24.6 lb
IN	G 1/2	
Pressione Min - Min Pressure	-0,15 BAR	- 2.17 P.S.I.
	-0,3 BAR (servizio discontinuo)	-0.435 P.S.I. (discontinuous service)
Pressione Max - Max Pressure	1 BAR	14.5 P.S.I.
OUT	G 1/2	
Max. Temperatura - Max. Temperature	60 °C	140 °F
Tipo olio - Oil type	SAE 30	
Capacità olio - Oil capacity	0,95 lt	0.25 U.S.G.

TABELLA RENDIMENTI PERFORMANCE CHART								
g/min R.P.M.	800		1000		1200		1450	
BAR P.S.I.	L/min USGPM	KW HP	L/min USGPM	KW HP	L/min USGPM	KW HP	L/min USGPM	KW HP
2 29	22,3 5,9	0,1 0,1	27,9 7,4	0,1 0,1	33,5 8,9	0,1 0,2	40,5 10,7	0,2 0,2
20 290	22,1 5,8	1,3 1,7	27,6 7,3	1,6 2,2	33,1 8,7	2,0 2,6	40,0 10,6	2,4 3,1
40 580	21,8 5,8	1,7 2,3	27,2 7,2	2,1 2,9	32,7 8,6	2,6 3,4	39,5 10,4	3,1 4,1
50 725	21,5 5,7	2,1 2,8	26,9 7,1	2,6 3,5	32,3 8,5	3,2 4,2	39,0 10,3	3,8 5,1

* Il peso si riferisce alla sola pompa senza motorizzazione.
* The weight is referred to just the pump without the motor.

Versioni Versions	Motore elettrico Electric motor	C 40.1
STD	Trifase 4,0 KW (C) Threephase 4,0 KW (C)	38.8600.97.3