

# B90 Series

## B90-150



179 l/m  
47.3 USGPM



max 12 BAR  
174 P.S.I.

### APPLICAZIONI - APPLICATIONS



SPRAYER  
SPRAYER



SERRE  
GREENHOUSES



DISINFESTAZIONE  
DISINFESTATION

### MEMBRANE - MEMBRANES



DESMOFAN

DURAMAX

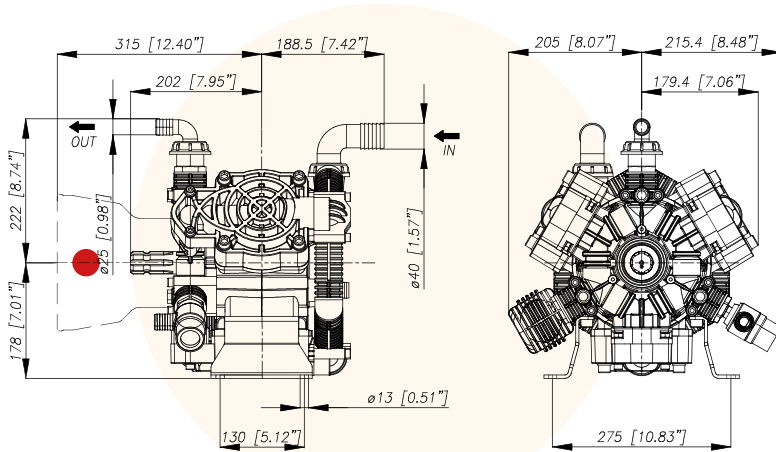

CARATTERISTICHE TECNICHE SPECIFICATIONS	550 g/min. 550 R.P.M.		TABELLA RENDIMENTI PERFORMANCE CHART								
	4,0 KW 5.4 HP	27 Kg 59.5 lb	g/min R.P.M.	400		450		500		550	
Potenza - Power			BAR P.S.I.	L/min USGPM	KW HP	L/min USGPM	KW HP	L/min USGPM	KW HP	L/min USGPM	KW HP
Peso - Weight			2	130	0,5	146	0,6	163	0,6	179	0,7
IN	$\varnothing 40$ mm	$\varnothing 1\frac{3}{15}$ in	29	34,4	0,7	38,7	0,8	43,0	0,9	47,3	0,9
Pressione Min - Min Pressure	-0,15 BAR	- 2.17 P.S.I.	5	128	1,3	144	1,4	160	1,6	176	1,7
Pressione Max - Max Pressure	1 BAR	14.5 P.S.I.	72,5	33,9	1,7	38,1	1,9	42,3	2,1	46,6	2,3
OUT	$\varnothing 25$ mm	$\varnothing 1$ in	10	126	2,0	142	2,2	158	2,5	174	2,7
Max. Temperatura - Max. Temperature	60 °C	140 °F	145	33,4	2,7	37,6	3,0	41,7	3,3	45,9	3,6
Tipo olio - Oil type	KLUBER CENTOPLEX GLP		12	124	2,9	140	3,3	156	3,7	171	4,0
Capacità olio - Oil capacity	0,3 lt	0.66 U.S.G.	174	32,9	3,9	37,0	4,4	41,1	4,9	45,2	5,4

### Versioni Versions

16.1001.97.3 - VS

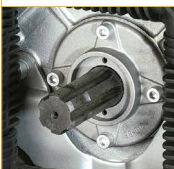

Anteriore/Front

Italian National Agency  
for Agricultural Mechanization



POLY Series