

3 "P" C-U Series

3 "P" C-U 110



1 l/m
0.3 USGPM



max 100 BAR
1450 P.S.I.

APPLICAZIONI - APPLICATIONS



UMIDIFICAZIONE
HUMIDIFICATION



RAFFRESCAMENTO
COOLING



NEBULIZZAZIONE
SPRAYING



FONTANE E GIOCHI D'ACQUA
FOUNTAINS AND WATER GAMES



SANIFICAZIONE
SANITIZATION

TECHNICAL PLUS:



USCITA ALBERO DX
RIGHT DRIVE SHAFT



BIELLE IN LEGA TONOLLI 328
CONRODS IN HYPER 328 TONOLLI ALLOY



GUARNIZIONI TENUTA ACQUA NBR (BUNA)
NBR (BUNA) WATER SEALS

OPTIONAL:



USCITA ALBERO LATO SX
LEFT DRIVE SHAFT



KIT PIEDINI IN LAMIERA D'ACCIAIO ZINCATI
GALVANIZED STEEL MOUNTING RAILS KIT

GUARNIZIONI - SEALS



GUARNIZIONI ANTERIORI
SUPER "U" - POSTERIORI "U"
SUPER "U" FRONT SEALS - "U"
BACK SEALS

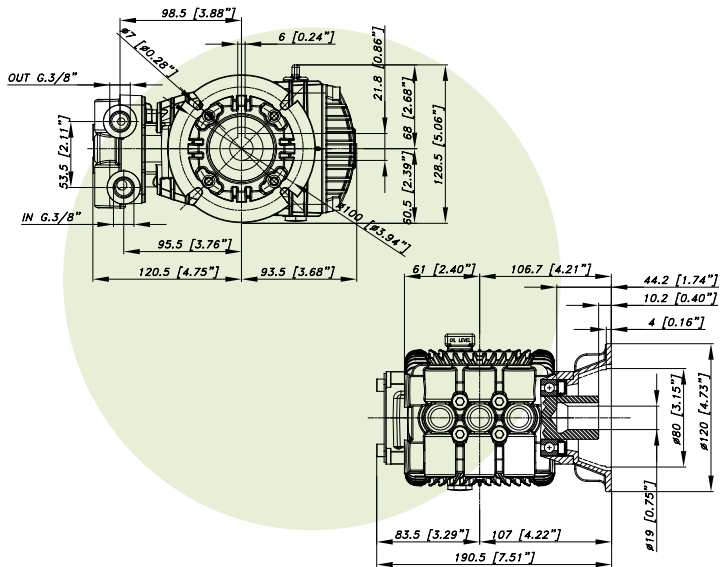

CARATTERISTICHE TECNICHE SPECIFICATIONS

Peso - Weight	5,5 Kg	12.1 lb
IN	3/8 BSP	
Pressione Min - Min Pressure	1 BAR	15 P.S.I.
Pressione Max - Max Pressure	6 BAR	87 P.S.I.
OUT	3/8 BSP	
Albero - Shaft	Ø 24 mm	
Max. Temperatura - Max. Temperature	60 °C	140 °F
Tipo olio - Oil type	SAE 75 - W 90	
Capacità olio - Oil capacity	0,5 lt	0.13 U.S.G.
Predisposta per motore - For Motor	IEC 80-B14-19 mm	

3 "P" C-U Series

3 "P" C-U 110

1 l/m
0.3 USGPM



max 100 BAR
1450 P.S.I.

3 "P" C-U

CODICE CODE	CODICE CODE	Press. Max Max Pres.		RPM 1000				RPM 1450				RPM 1450				Pist. Plung.	Corsa Stroke
		BAR	P.S.I.	L/min	GPM	KW	HP	L/min	GPM	KW	HP	L/min	GPM	KW	HP		
02.7080.97.3	3 "P" C-U 110	100	1450	0,7	0,2	0,1	0,2	0,9	0,2	0,2	0,2	1,0	0,3	0,2	0,3	13	3
02.7081.97.3	3 "P" C-U 210	100	1450	1,7	0,4	0,3	0,4	2,1	0,5	0,4	0,5	2,4	0,6	0,5	0,6	13	4,8
02.7082.97.3	3 "P" C-U 310	100	1450	2,1	0,6	0,4	0,6	2,7	0,7	0,5	0,7	3,0	0,8	0,6	0,8	13	6
02.7083.97.3	3 "P" C-U 410	100	1450	2,9	0,8	0,6	0,8	3,6	0,9	0,7	0,9	4,1	1,1	0,8	1,1	13	8

Predisposta per motore For Motor

IEC 80 B14-19 mm

02.7080.97.3

